

CRM Issues CRM

2002. 3.

YI.YOO@NCR.COM



CRM Review

- CRM Redefine

-

-

- CRM

- CRM Issues

CRM CSF

-

-

-

- CRM Intelligence Model

- CRM

- Closed Loop CRM

- CRM

- 가 CRM

- Enabler Technology

- CRM

- / /

CRM

- Operational & Analytical CRM

- CRM EDW

- CRM

- ON/OFF Line

- CRM

- 가

CRM

- Customer Insight

- Strategy

- Process

- Organization

- IT Infrastructure

- Change Management

CRM Redefine - CRM

....

(Transformation) / , CRM (Customer-Centric Enterprise) 가 .

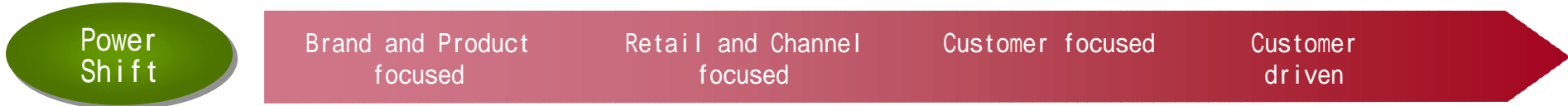
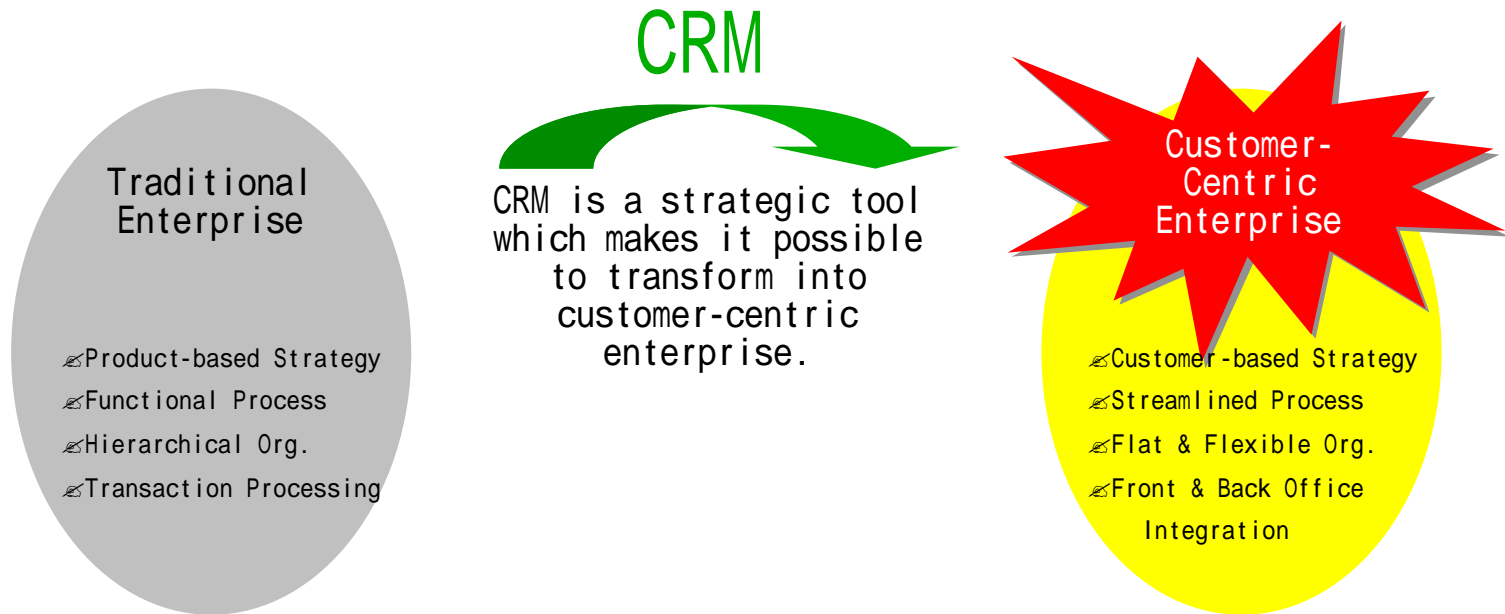

가

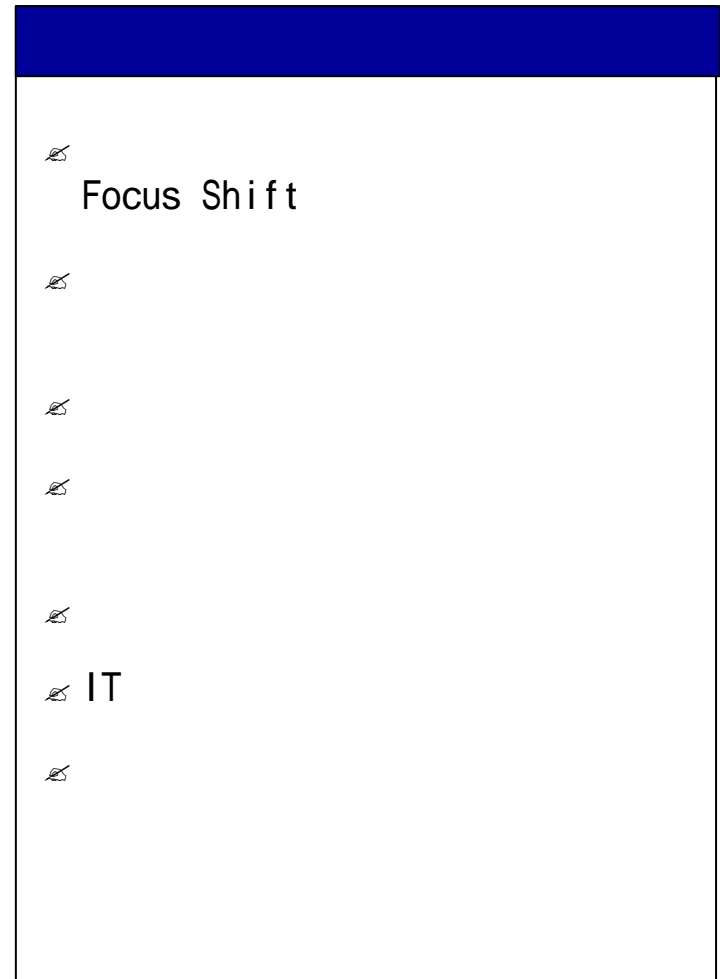
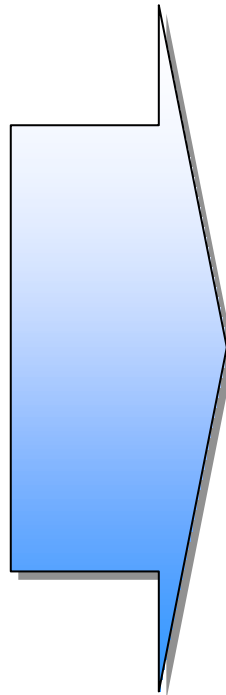
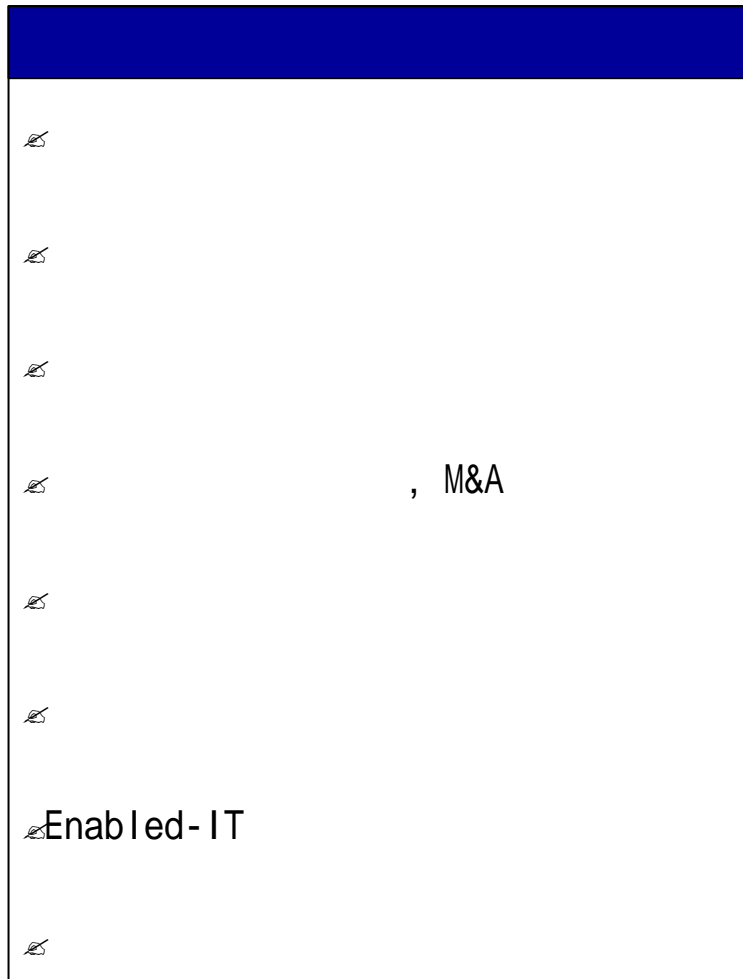

/ 가
/ 가

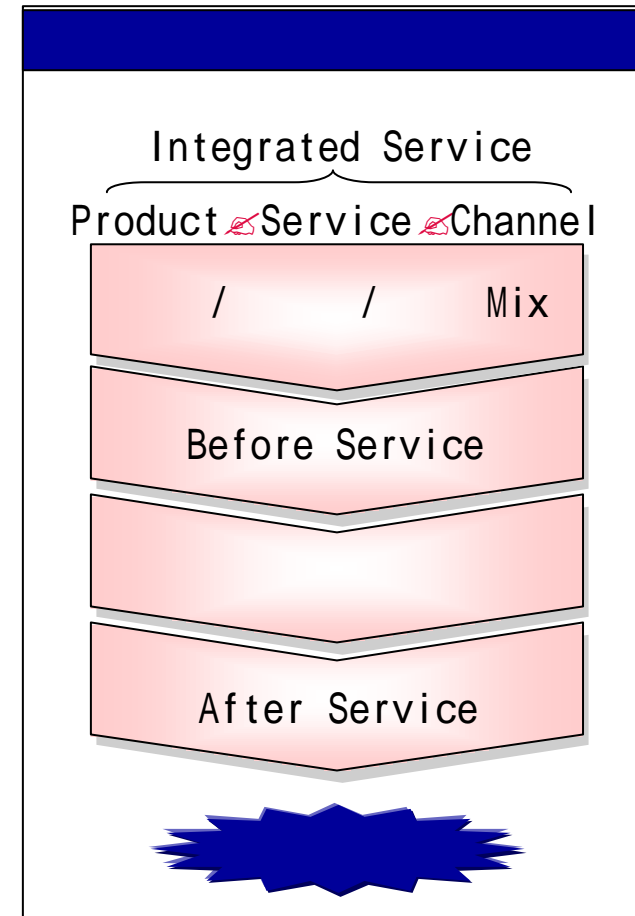
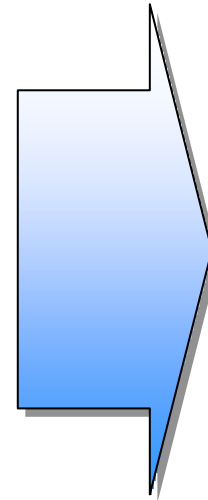
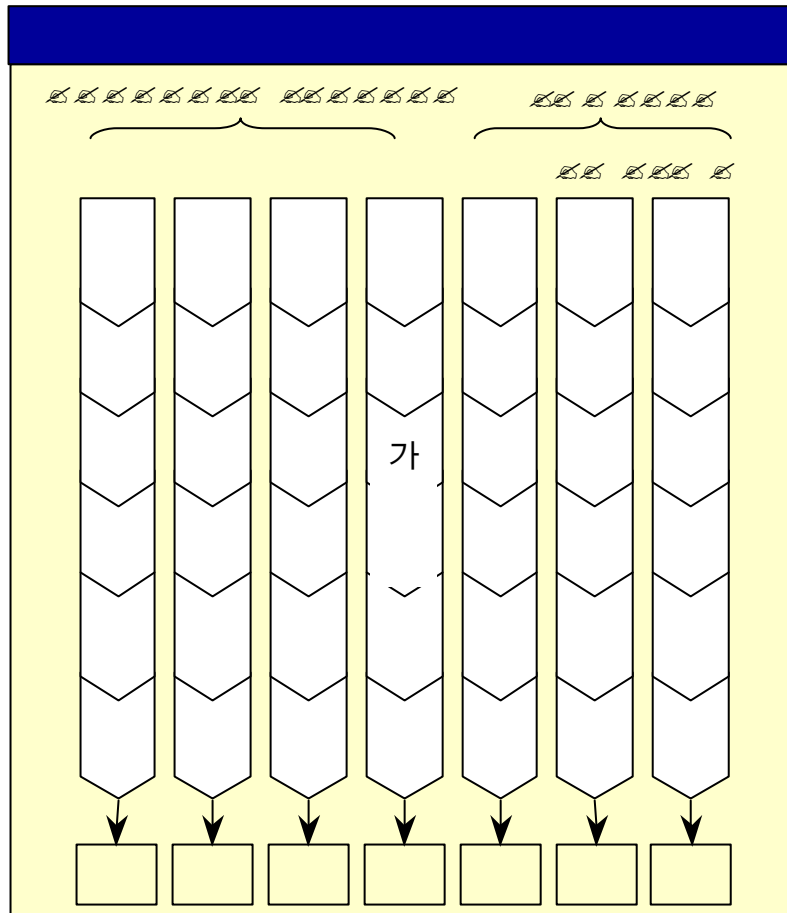

CRM

CRM

CRM

가

	Banking	High Tech	Insurance	Manufacturing	Retail	Telecom	Other
/		20%	14%	8%	67%	20%	
/ 가	40%	20%	14%	23%	33%	60%	33%
IT	40%	20%	71%	69%	33%	0%	17%
CRM	60%	80%	43%	62%	67%	20%	50%
cross functional	60%	60%	29%	38%	67%	60%	17%
&	20%	20%	71%	15%	33%	60%	50%
	20%	40%	14%	15%	33%	20%	33%
	20%	20%	43%	31%	0%	60%	17%
&	20%	20%	43%	15%	33%	20%	33%
	20%	40%	14%	23%	33%		50%

Source: META Group, CRM Study

CRM Issues

CRM

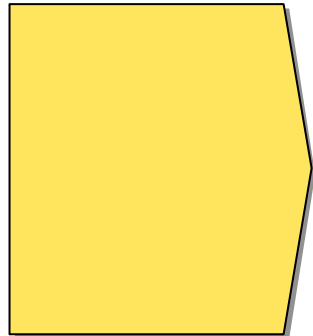

Value / Needs
가
Intelligence Model

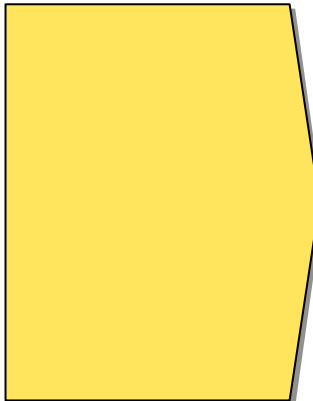

가 CRM
Solution/System
issues
IT / - Enabler IT
ROI

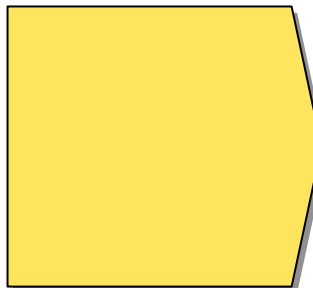

가
Closed loop
Sales Customer Care

CRM Issues()



~~CRM~~ / /

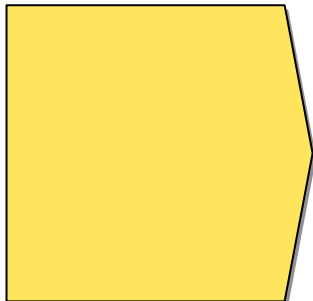

~~CRM~~ CRM
~~CRM~~
~~CRM~~ (, , ,)
~~CRM~~

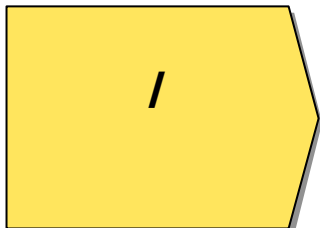

~~가~~ / 가

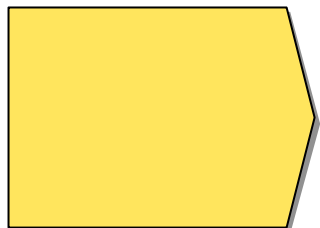

~~CRM~~ CRM
~~CRM~~
~~CRM~~

CRM Issues - ()

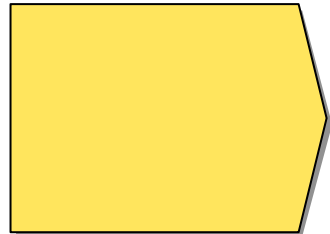

CRM issues
Closed Loop

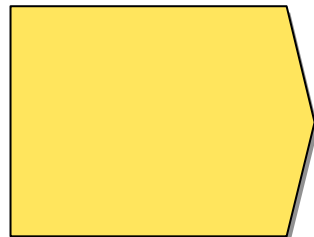

Online & Offline
Digital



ROI

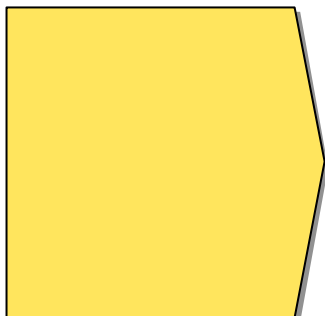

CRM DW
가 EDW /
,

☞ CRM Review

- CRM Redefine
-
-
- CRM
- CRM Issues

☞ CRM CSF

-
-
-
- CRM Intelligence Model
- CRM
- Closed Loop CRM
- CRM
- 가 CRM
- Enabler Technology
- CRM

- / /
- CRM
- Operational & Analytical CRM
- CRM EDW
- CRM
- ON/OFF Line
- CRM
- 가

☞ CRM

- Customer Insight
- Strategy
- Process
- Organization
- IT Infrastructure
- Change Management

CRM CSF -

✍ Top-down/Bottom-up

- Customer Object view
- Customer Information Analysis view

✍ /

- /

-

-

-

-

-

✍

-

- /

- (, , /)

-

CRM CSF -

()



-Top Down & Bottom Up

- Segment Objective : differentiation & effectiveness
- Catch Interesting Dimension

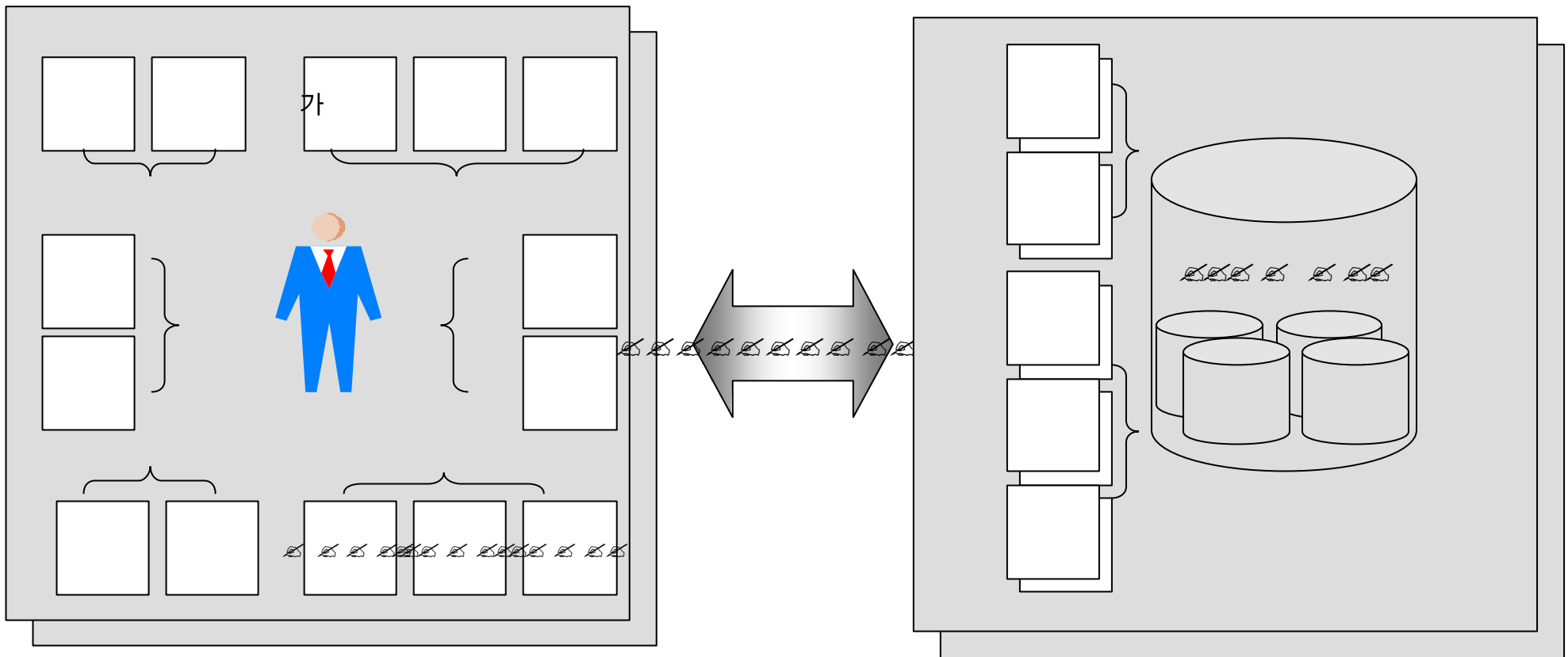

CRM CSF -

()

 CRM

-
-
-
-



 CRM

-
-
-
-





-

/ /

CRM CSF - CRM

Intelligence Model

()

CRM
Model

Intelligence

Intelligence Model

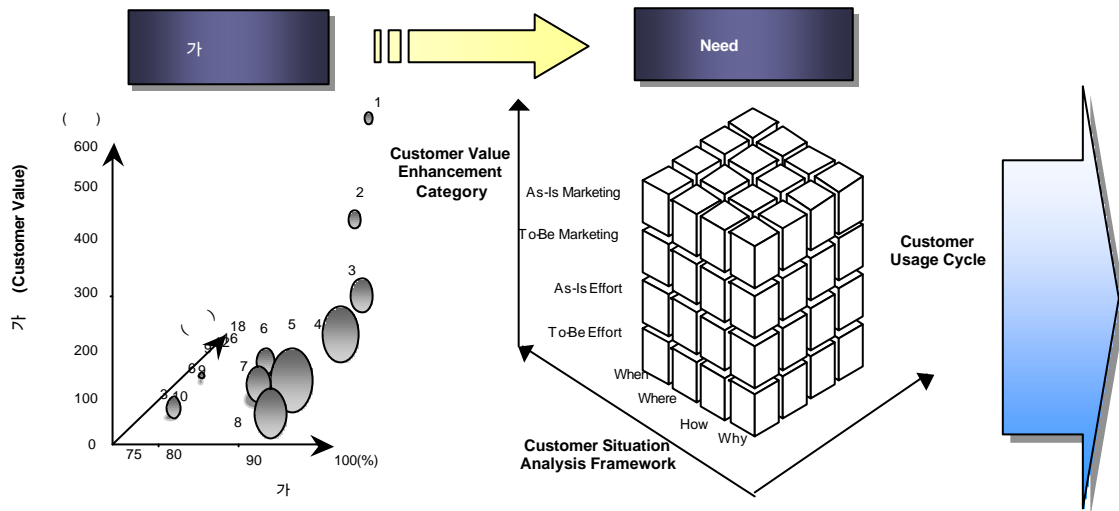

- 가
- 가
- RFM
- 가
- 가
- 가
- 가
- Life Stage
- 가
- 가
- 가
- 가

CRM CSF -

CRM ()

(Customer-Centric Enterprise)
Strategy, Business Process, IT, Organization
Strategy

Customer/Channel/ Product
Transformation

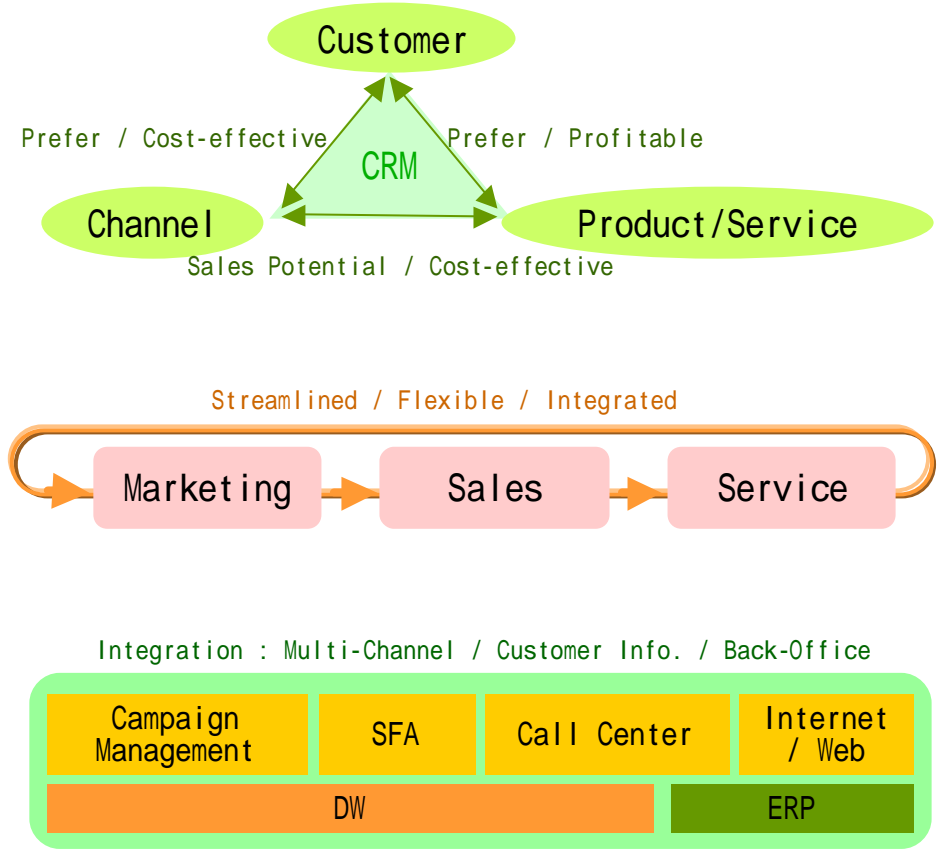
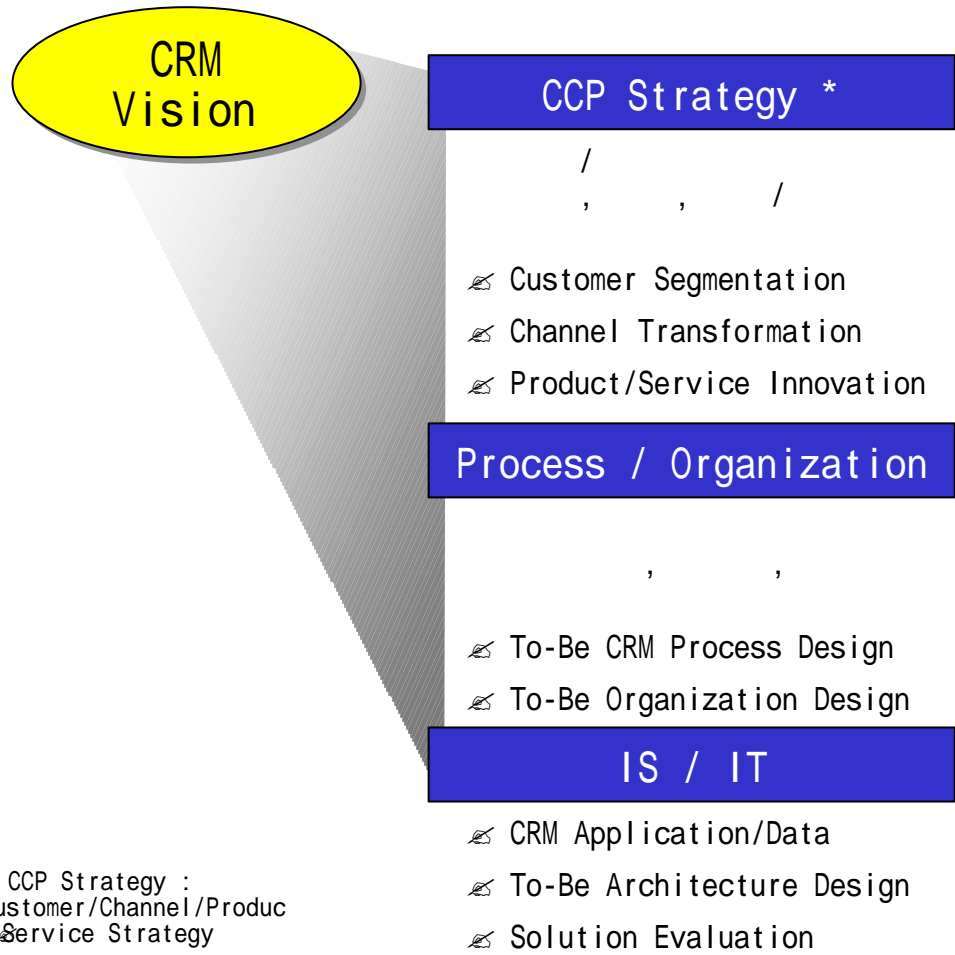

* CCP Strategy :
Customer/Channel/Product/Service Strategy

CRM CSF - CRM ()

CRM
3가

Assessment, Vision & Strategy,

Action Plan

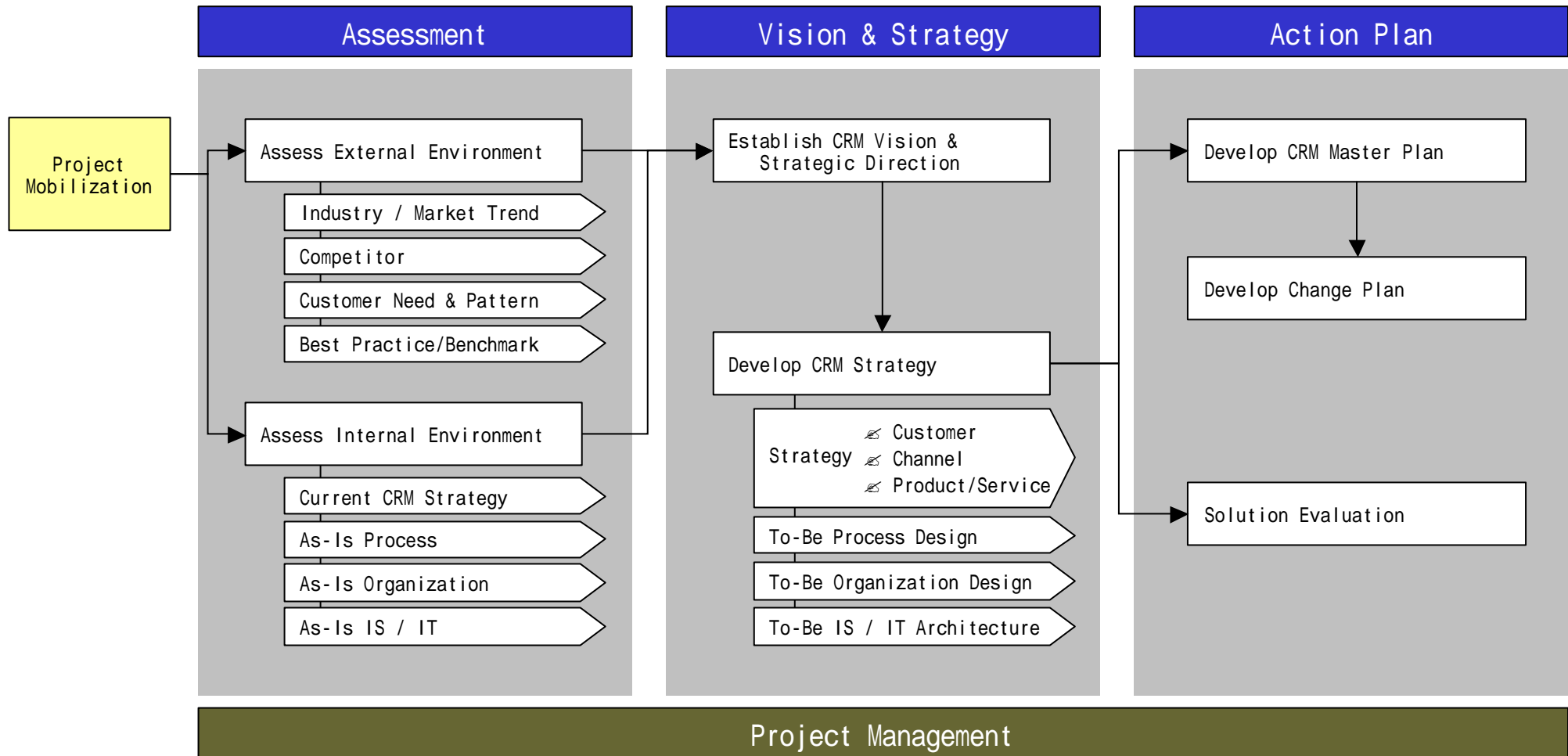

CRM CSF - Closed Loop CRM

()

CRM

Closed Loop

가

Closed Loop CRM Process

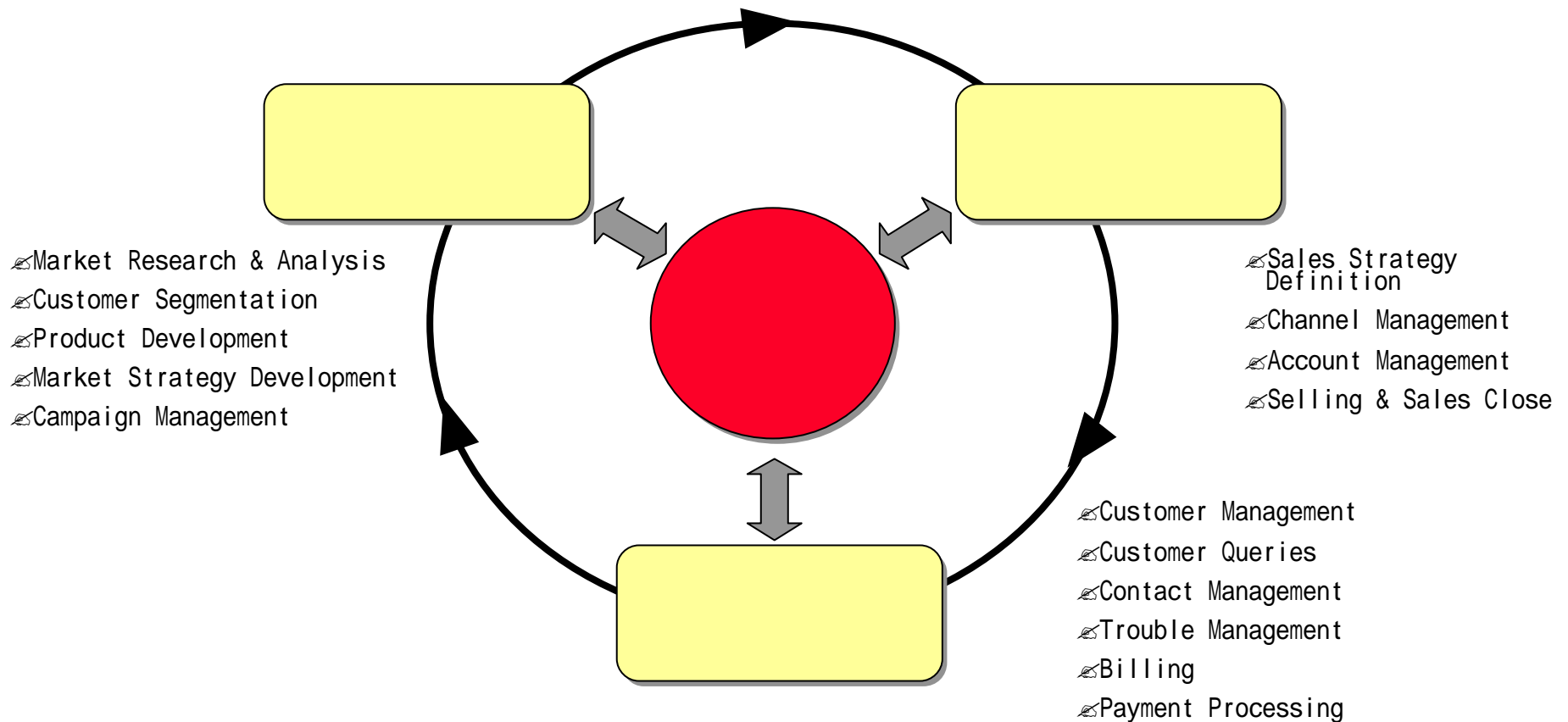

CRM CSF -

CRM

()

, / 가 CRM .

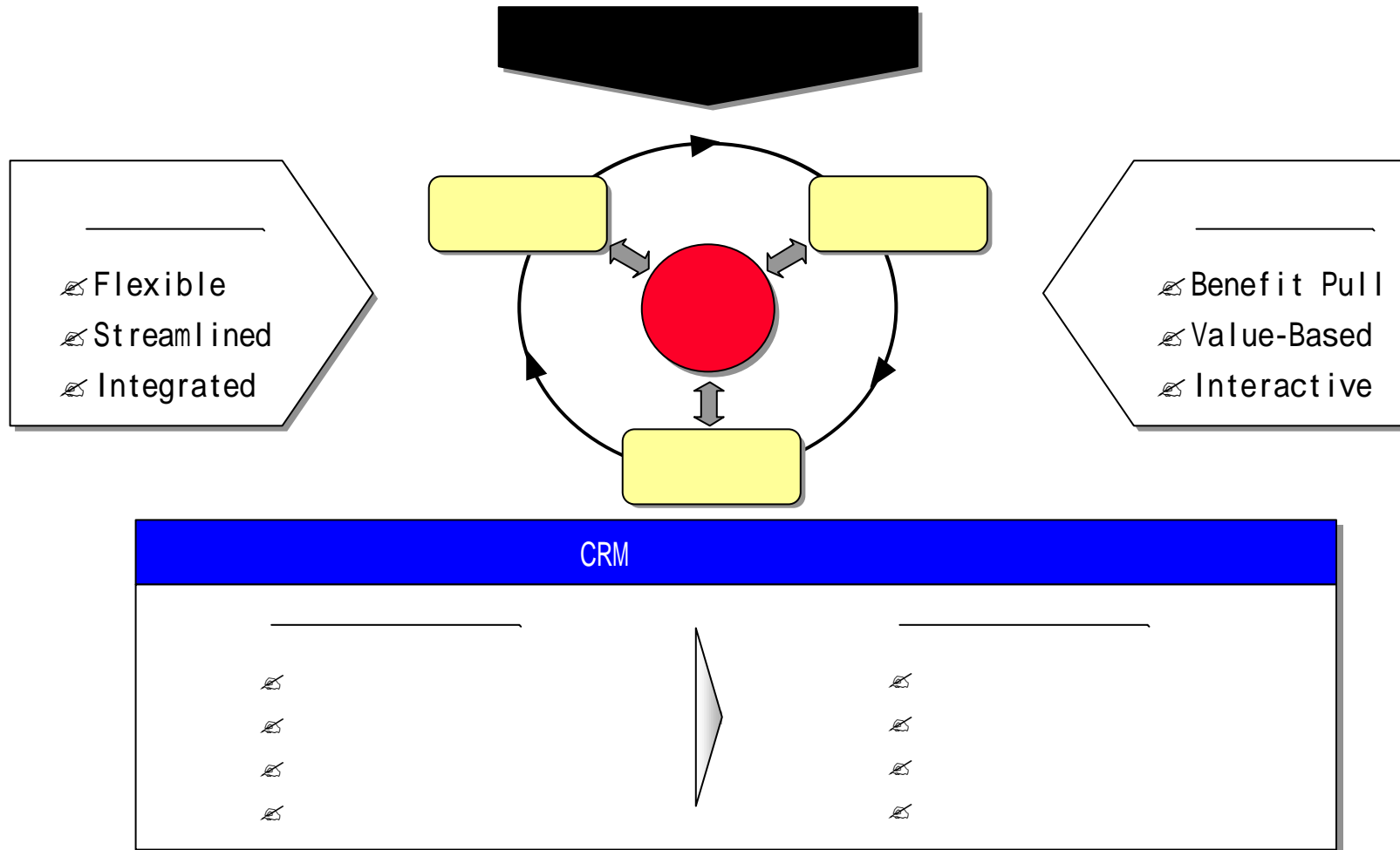

가

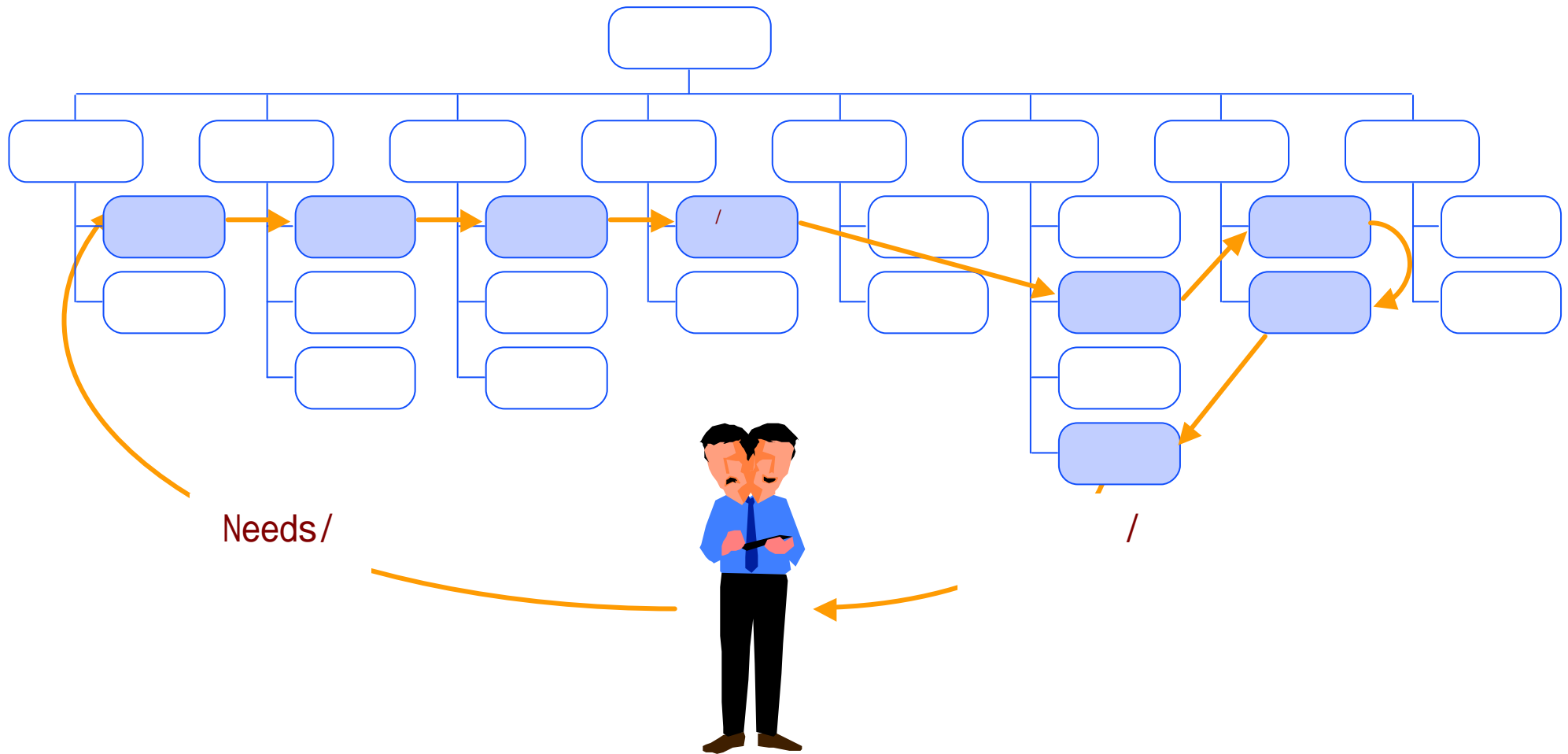

Needs/

/

CRM CSF - Enabler Technology

()

Enabler IT

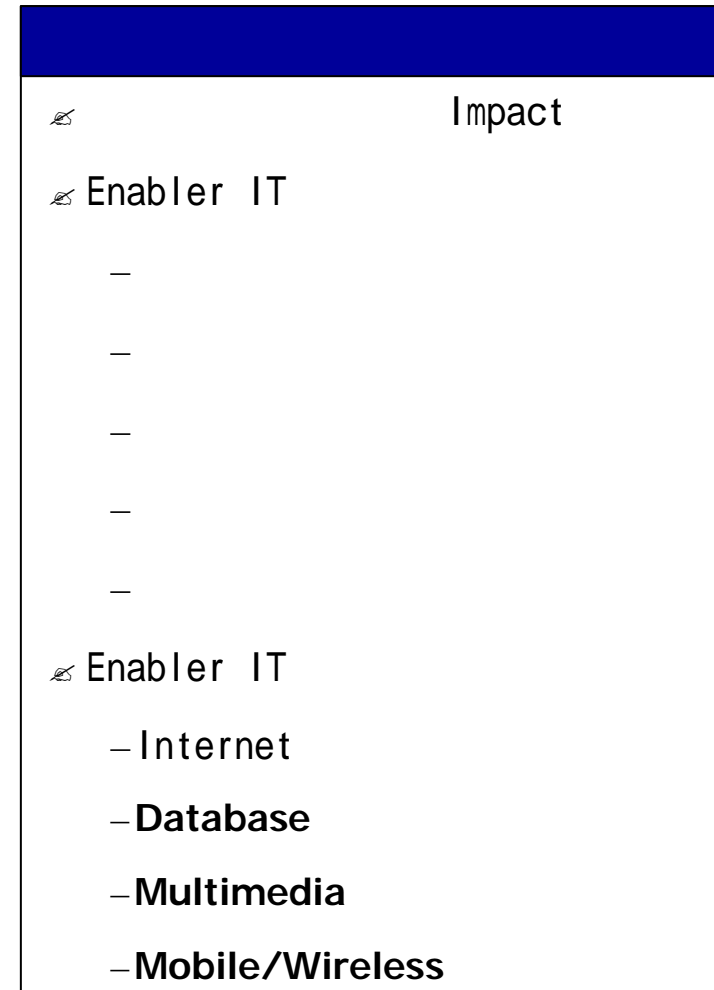
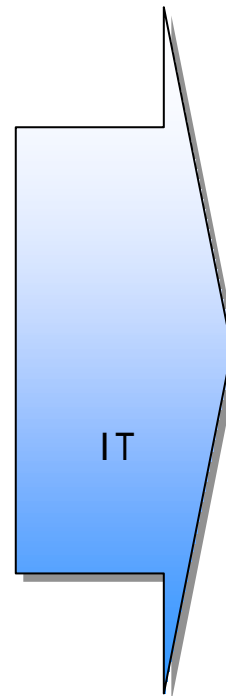
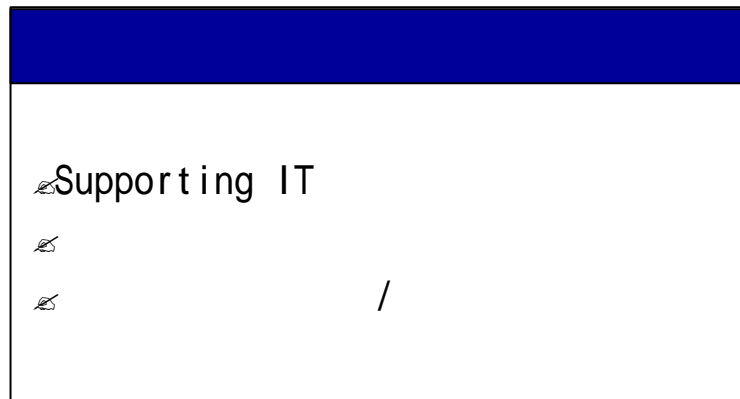

CRM CSF -

CRM ()

CRM

/

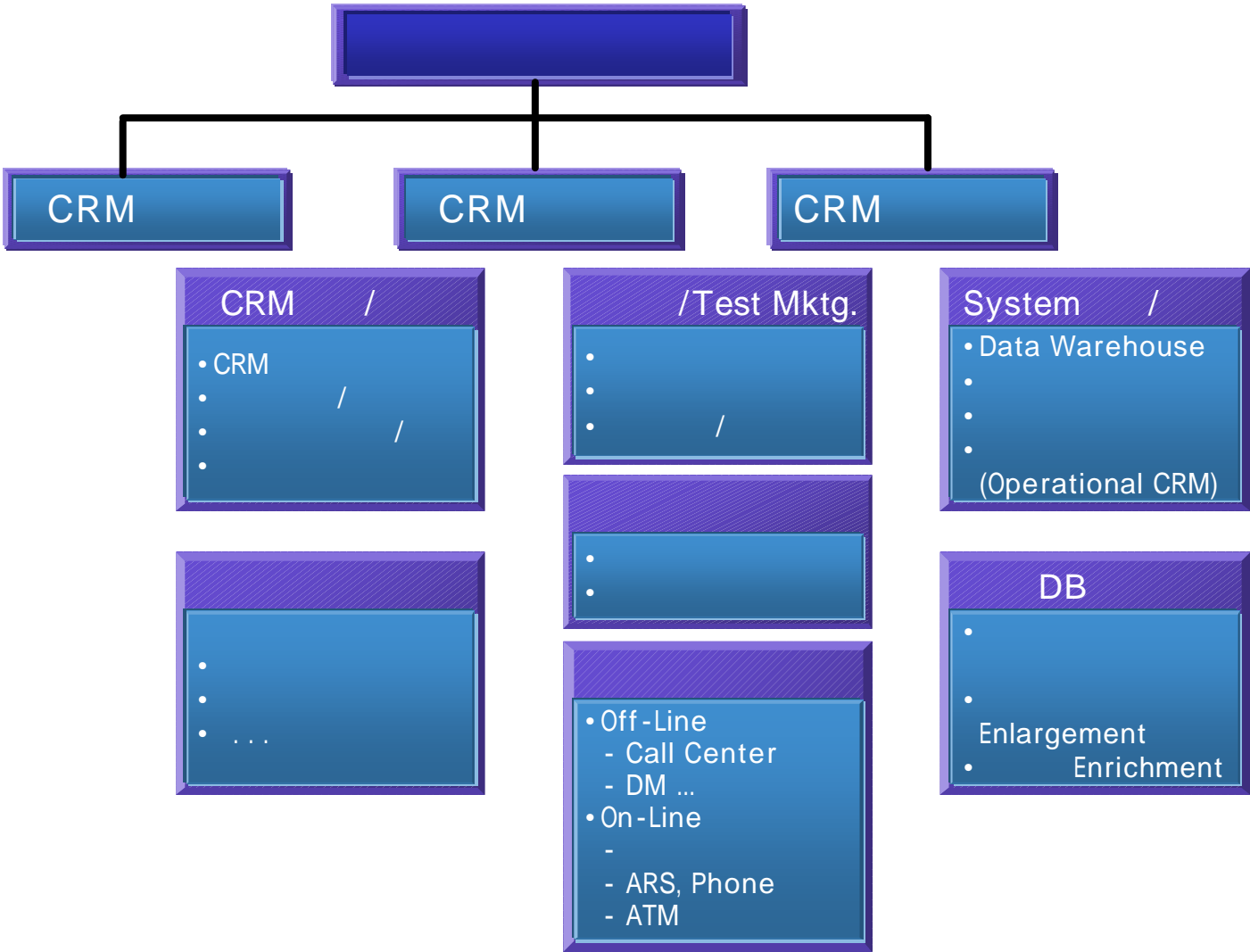

CRM CSF - / / / CRM

CRM Architecture

가

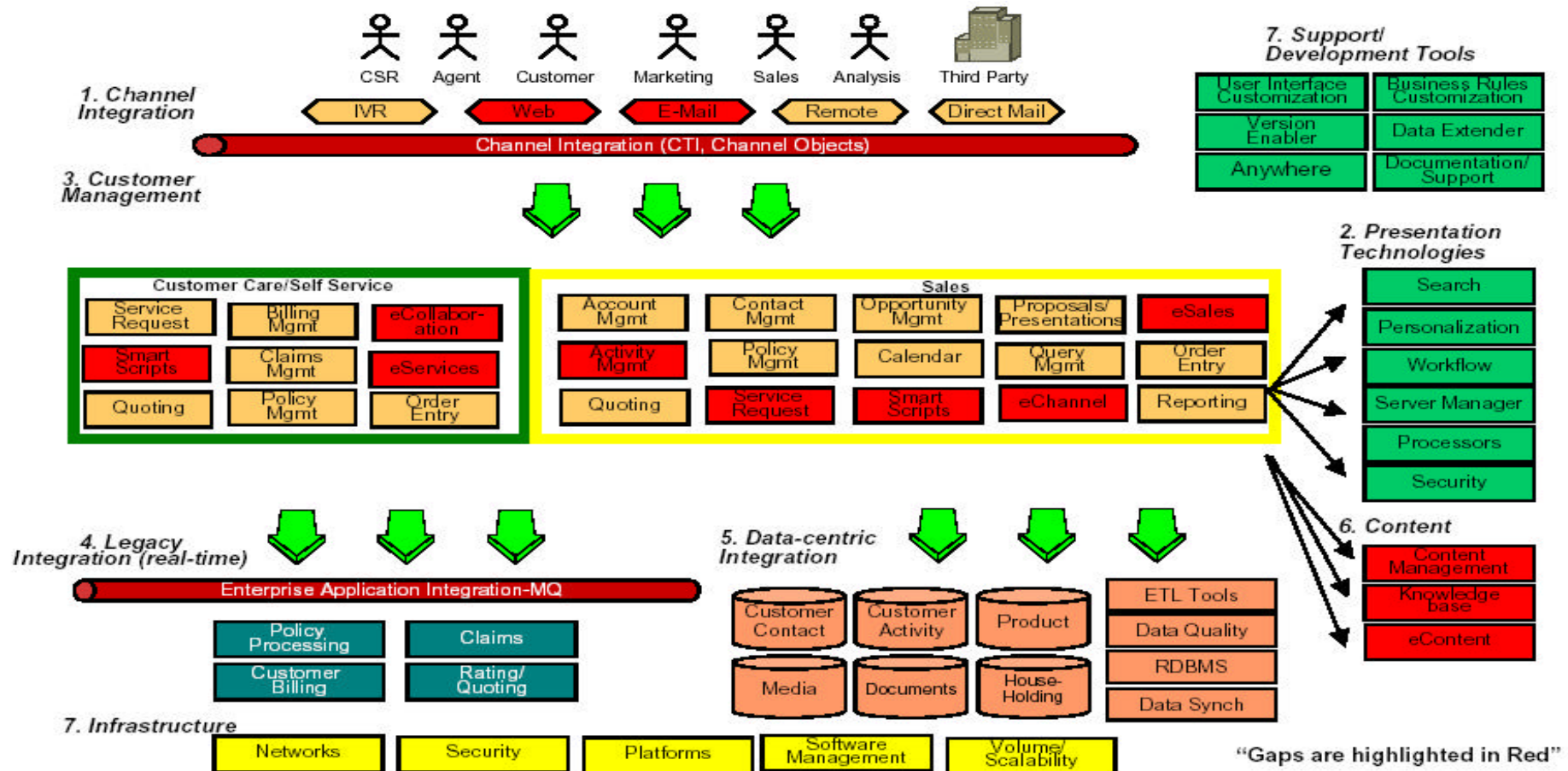

CRM CSF - Operational & Analytical CRM ()

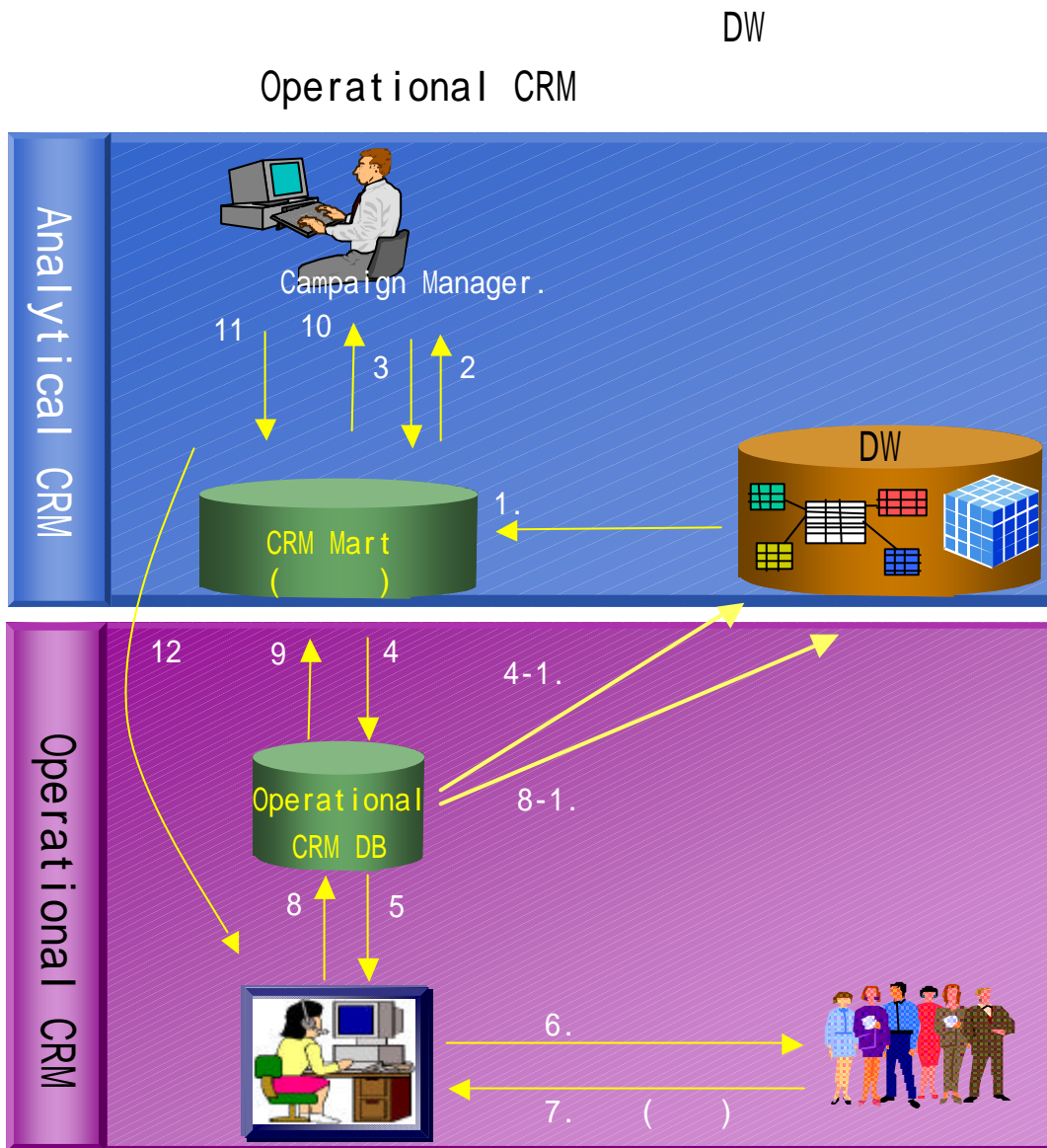

DW

Analytical CRM

Operational CRM

Analytical CRM

Campaign Manager.

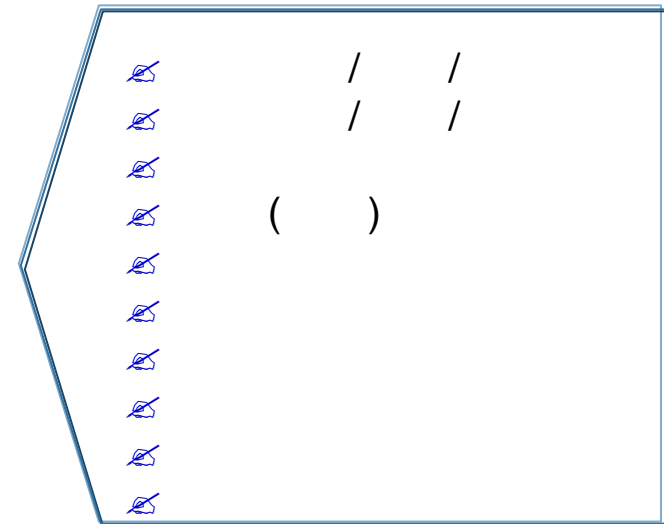
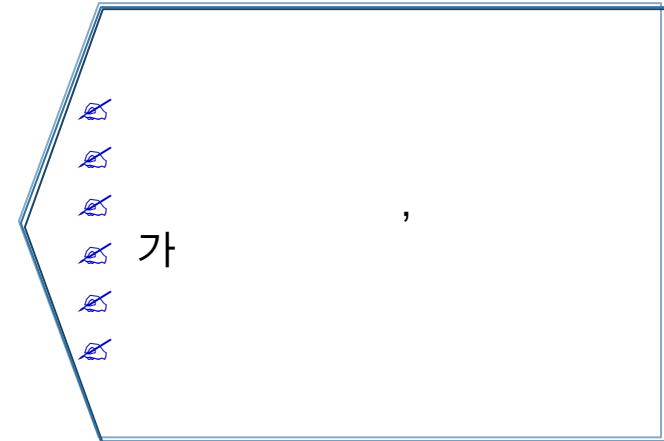
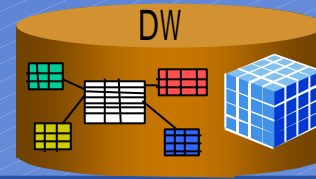
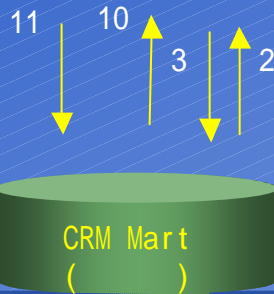

CRM CSF - CRM

EDW

()

CRM

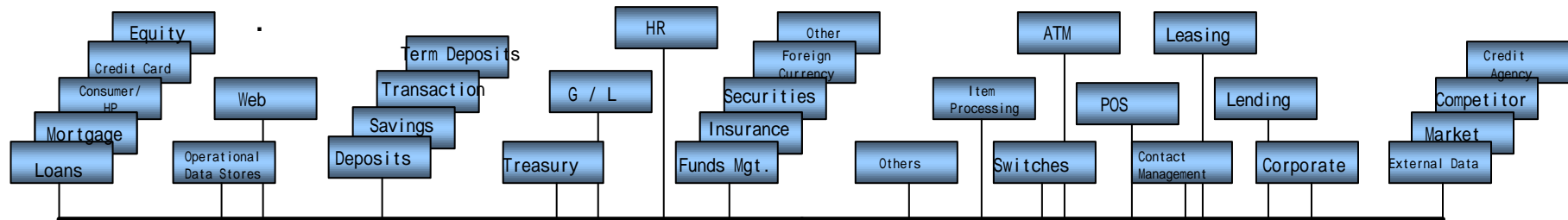

TYPES OF DATA SOURCES

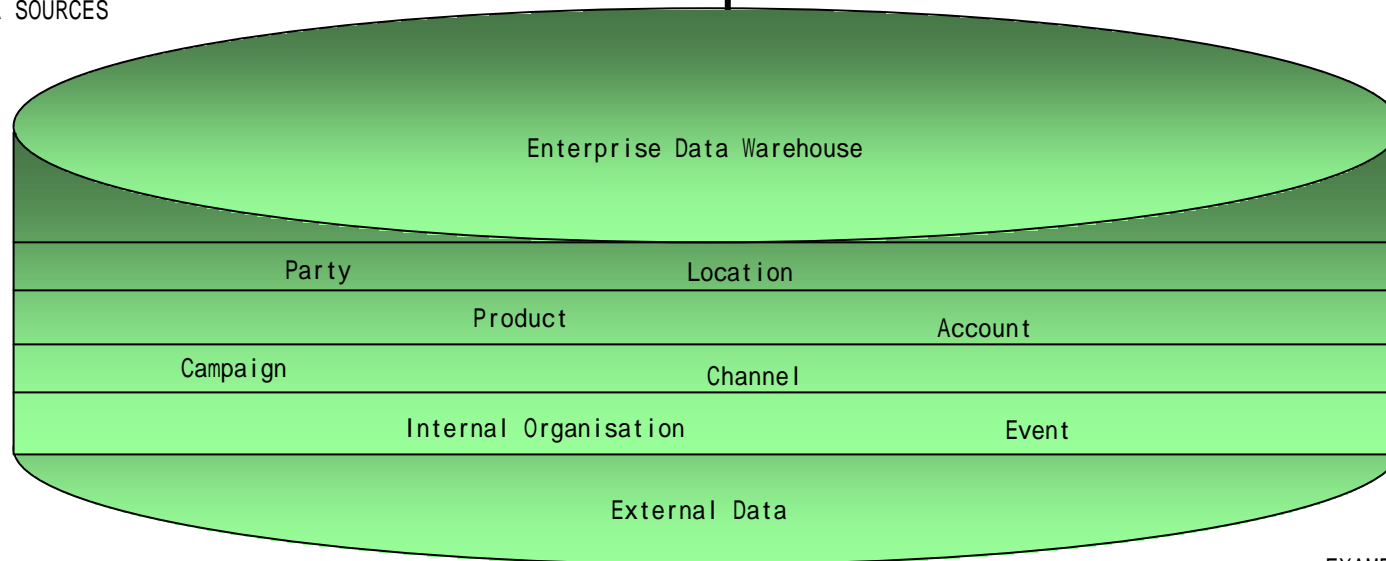

EXAMPLES OF ANALYTICS

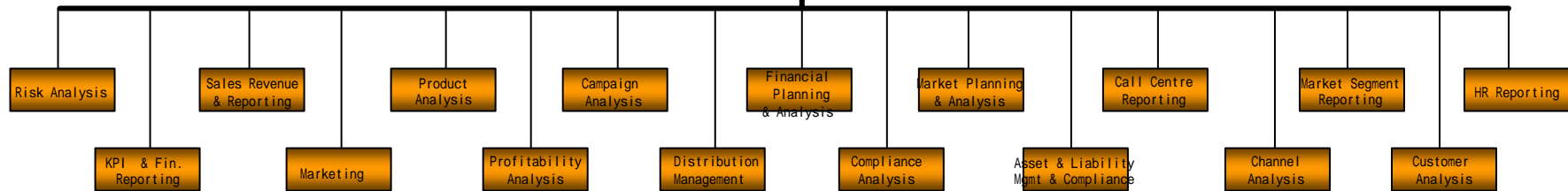

CRM CSF - CRM

()

CRM

On/Off line

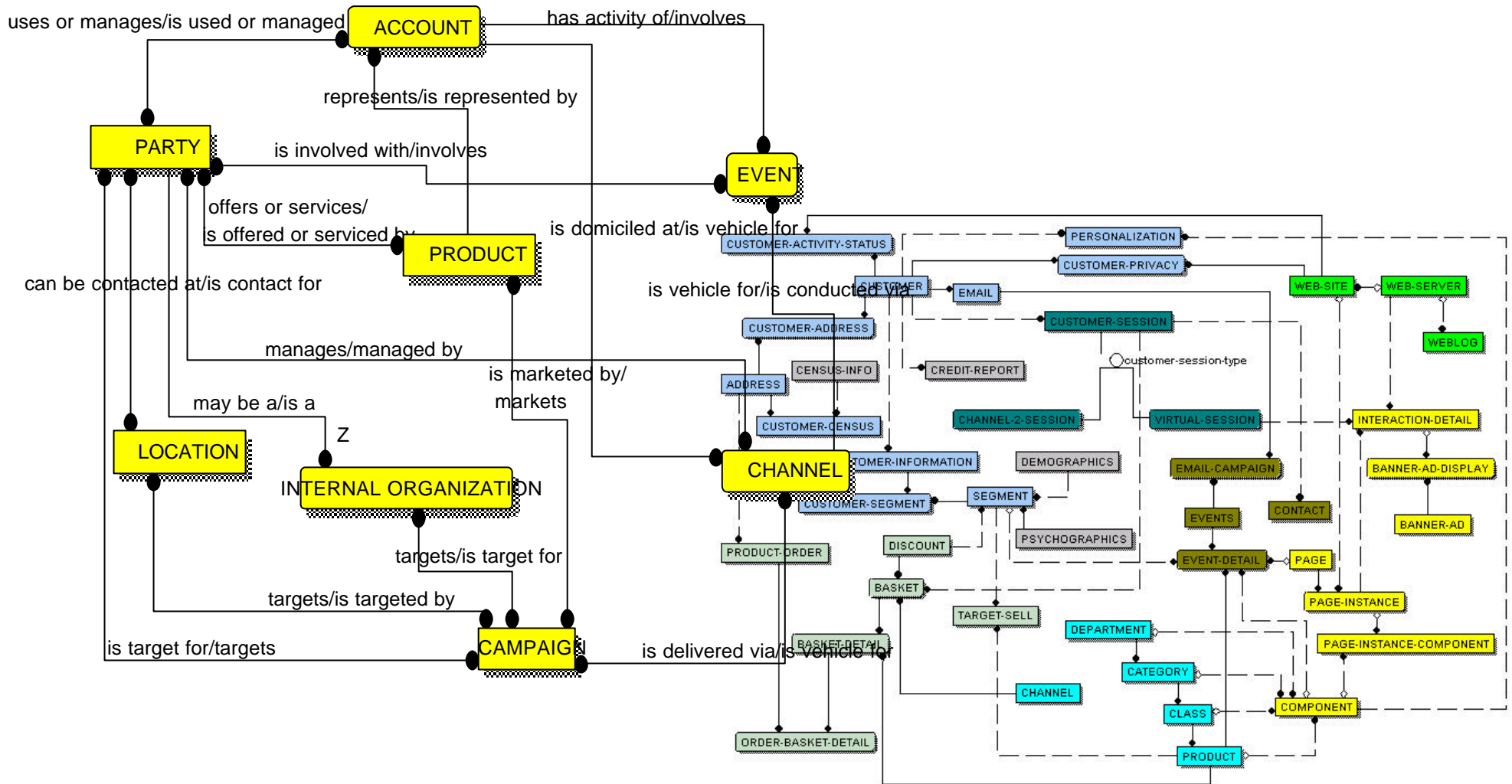

CRM

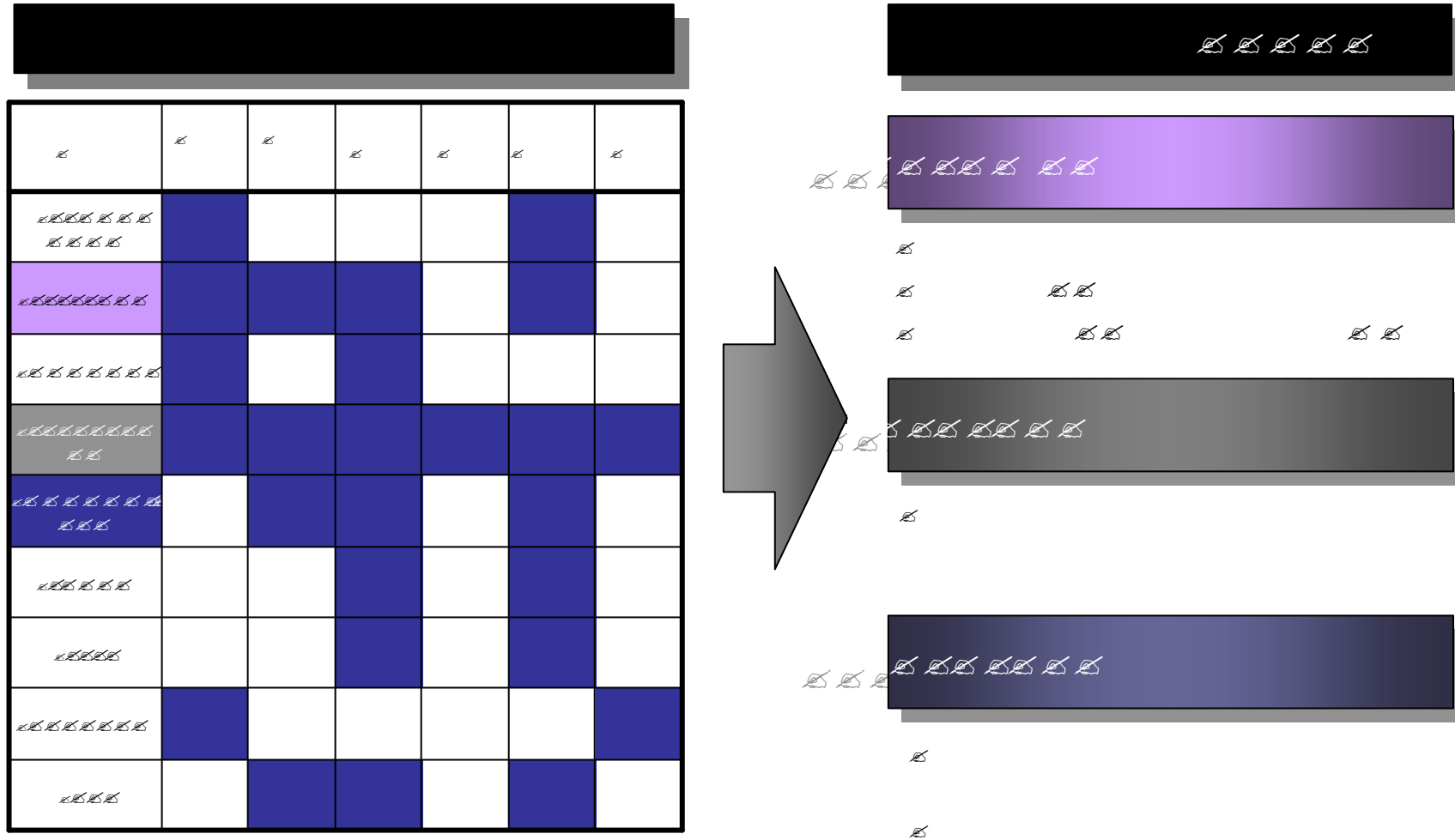

CRM CSF -

()

, ,

.

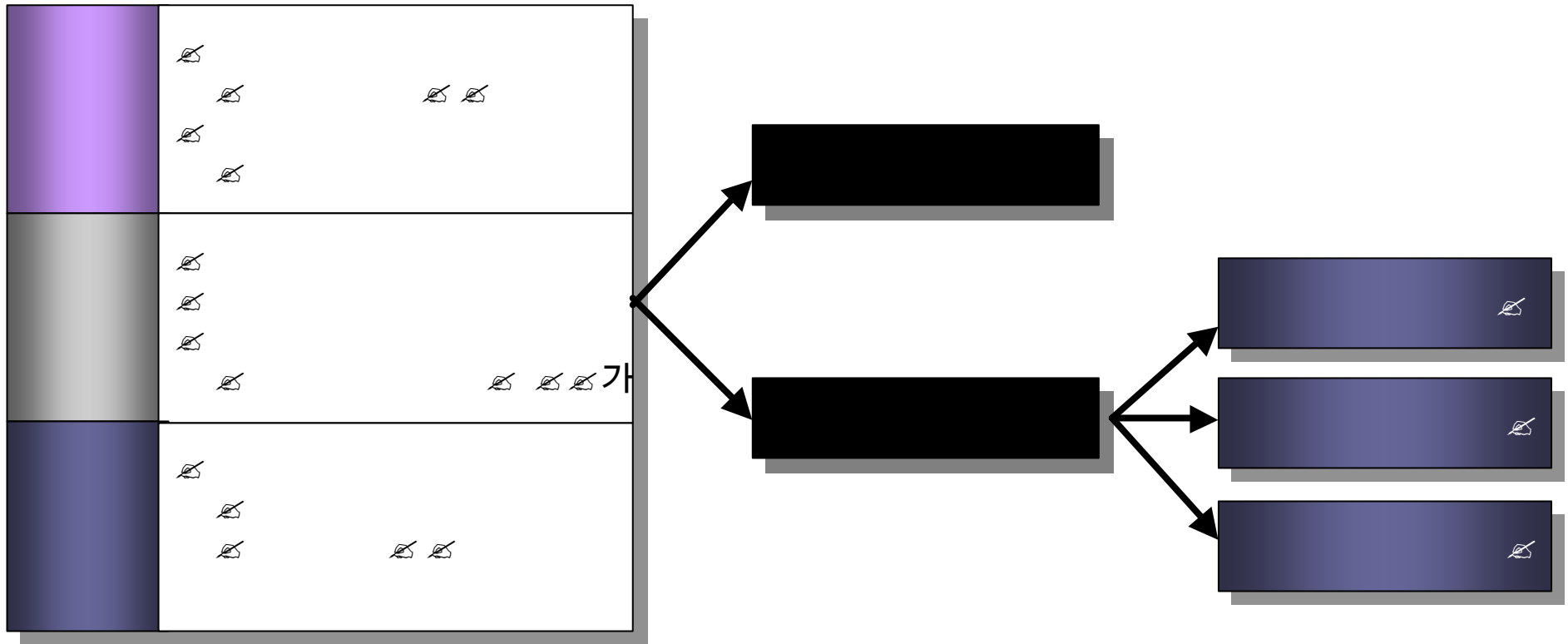

CRM CSF - CRM

()

CRM 가, 가, E-BIZ. 가, CRM Marketer, 가, 가, 가, .

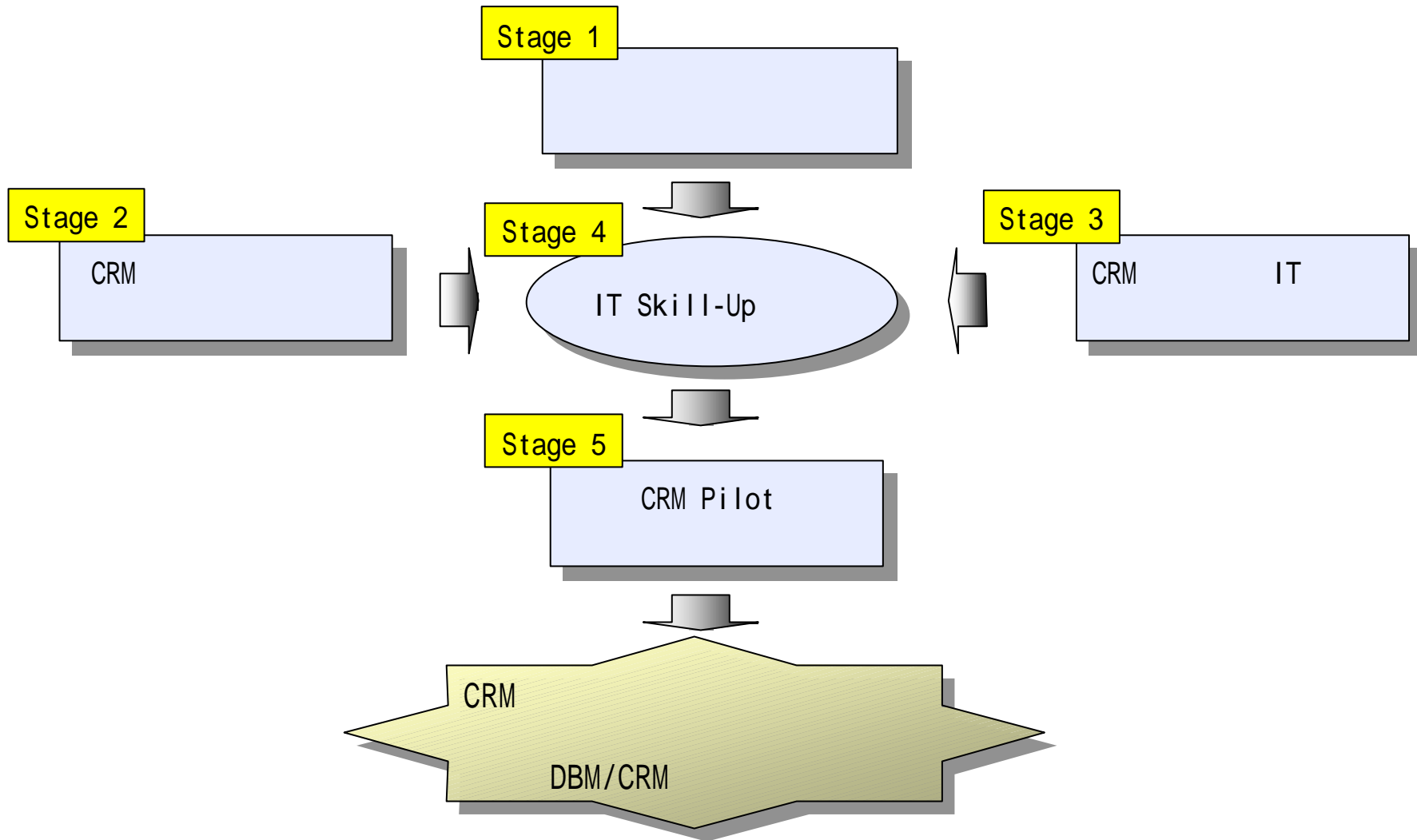

GAP

가

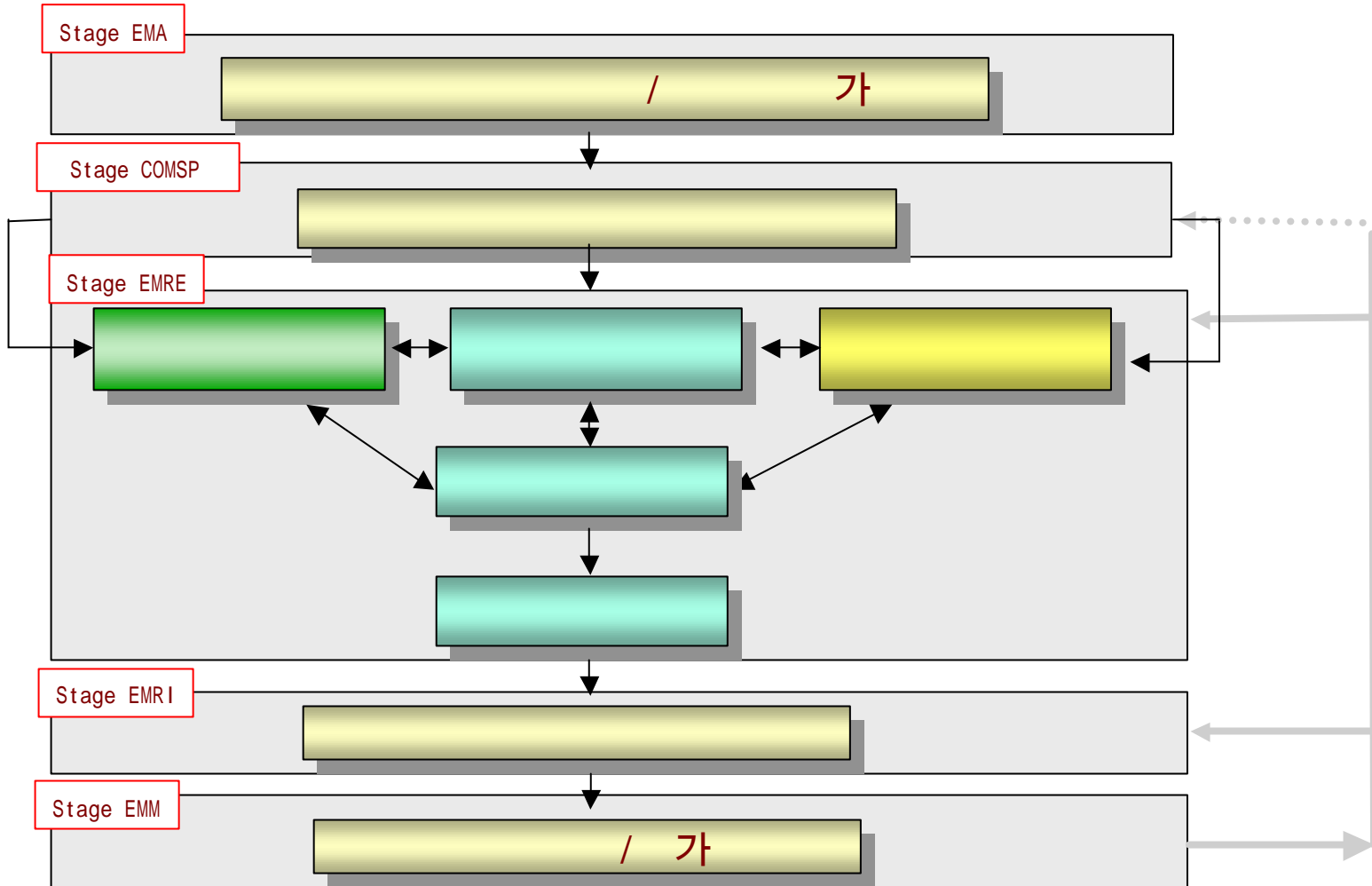

☞ CRM Review

- CRM Redefine
-
- CRM
- CRM Issues

☞ CRM CSF

-
-
- CRM Intelligence Model
- CRM
- Closed Loop CRM
- CRM
- 가 CRM
- Enabler Technology
- CRM

- / /
- CRM
- Operational & Analytical CRM
- CRM EDW
- CRM
- ON/OFF Line
- CRM
- 가

☞ CRM

- Customer Insight
- Strategy
- Process
- Organization
- IT Infrastructure
- Change Management

CRM

6가

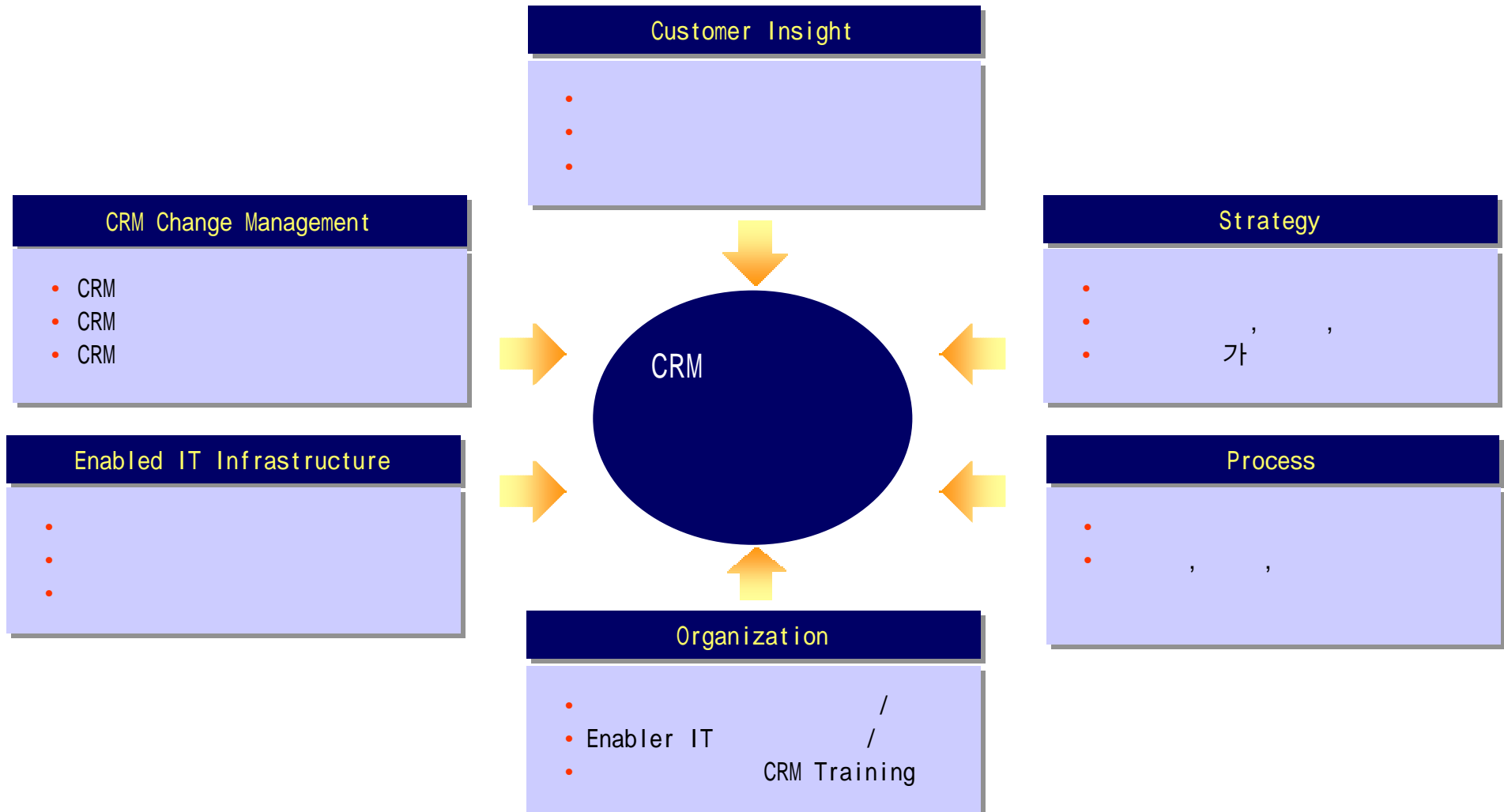

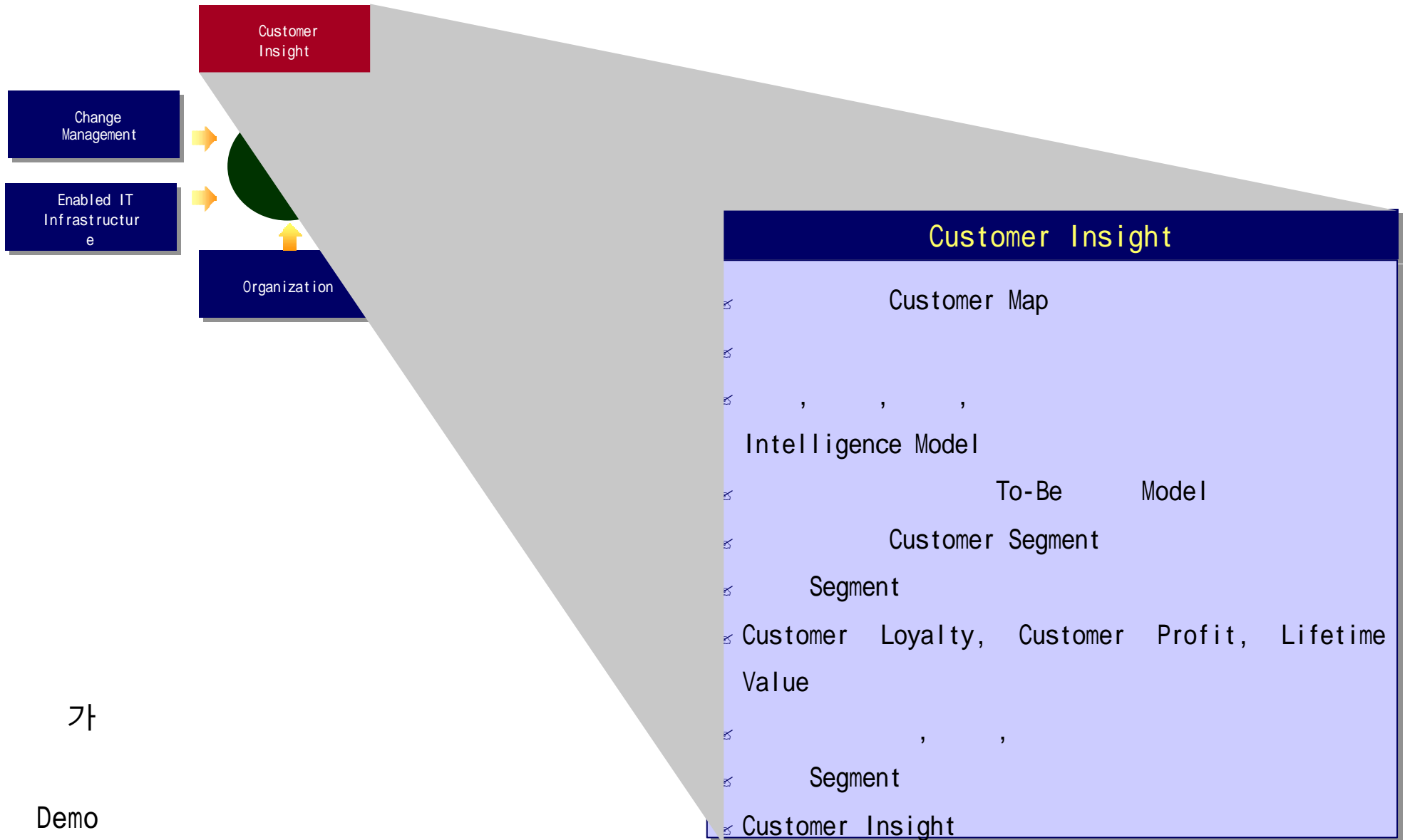

가

Demo

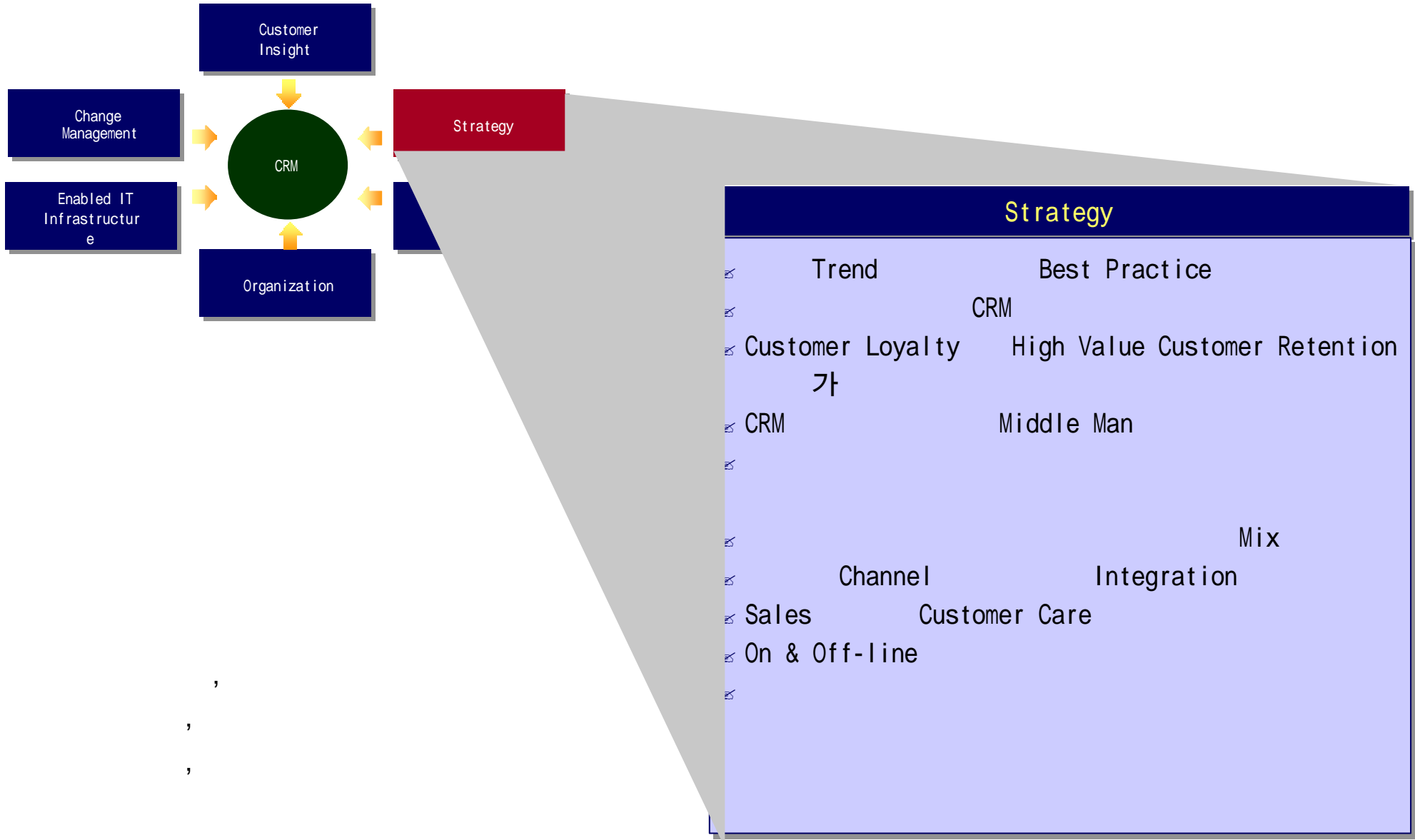

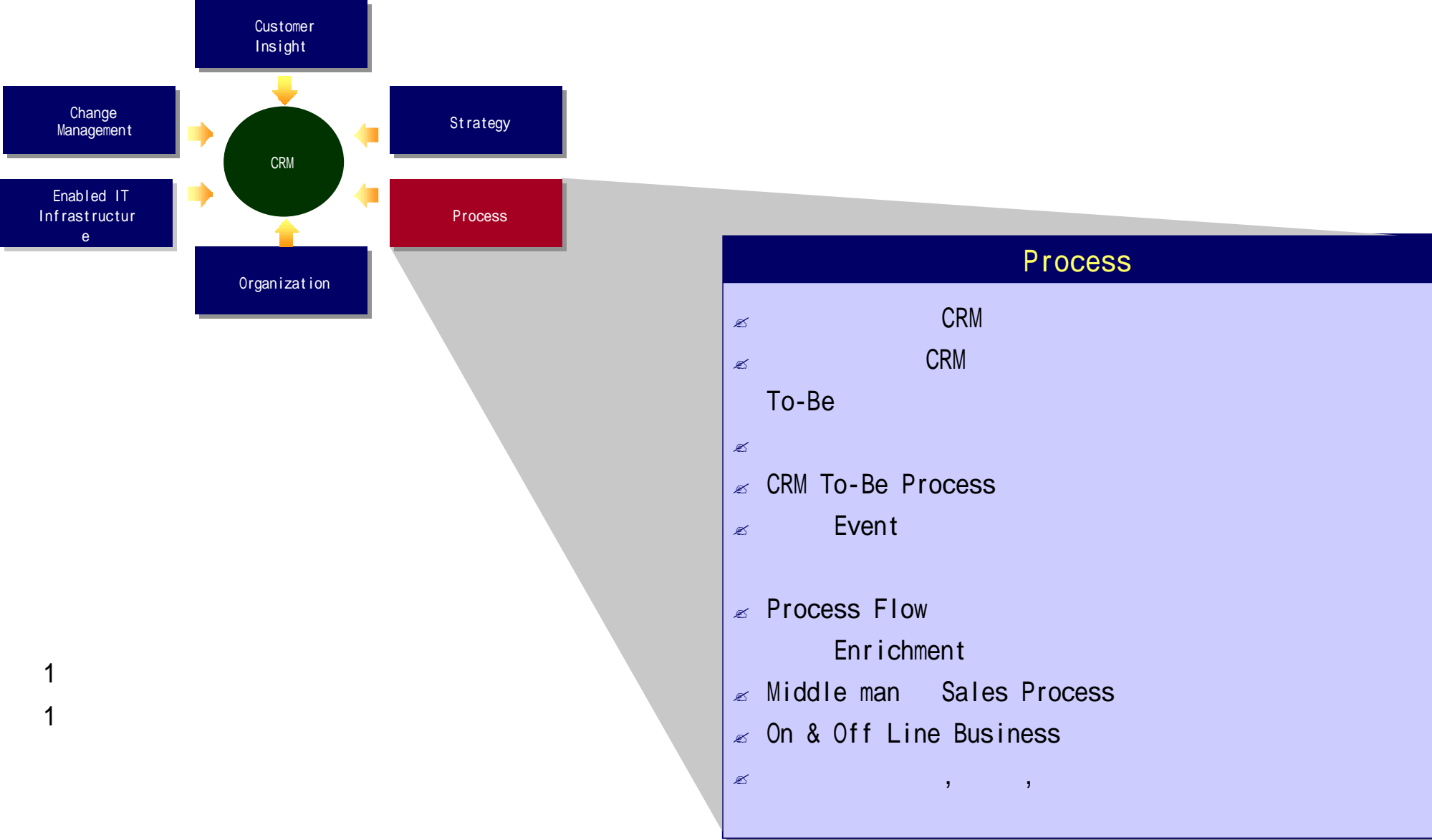

1
1

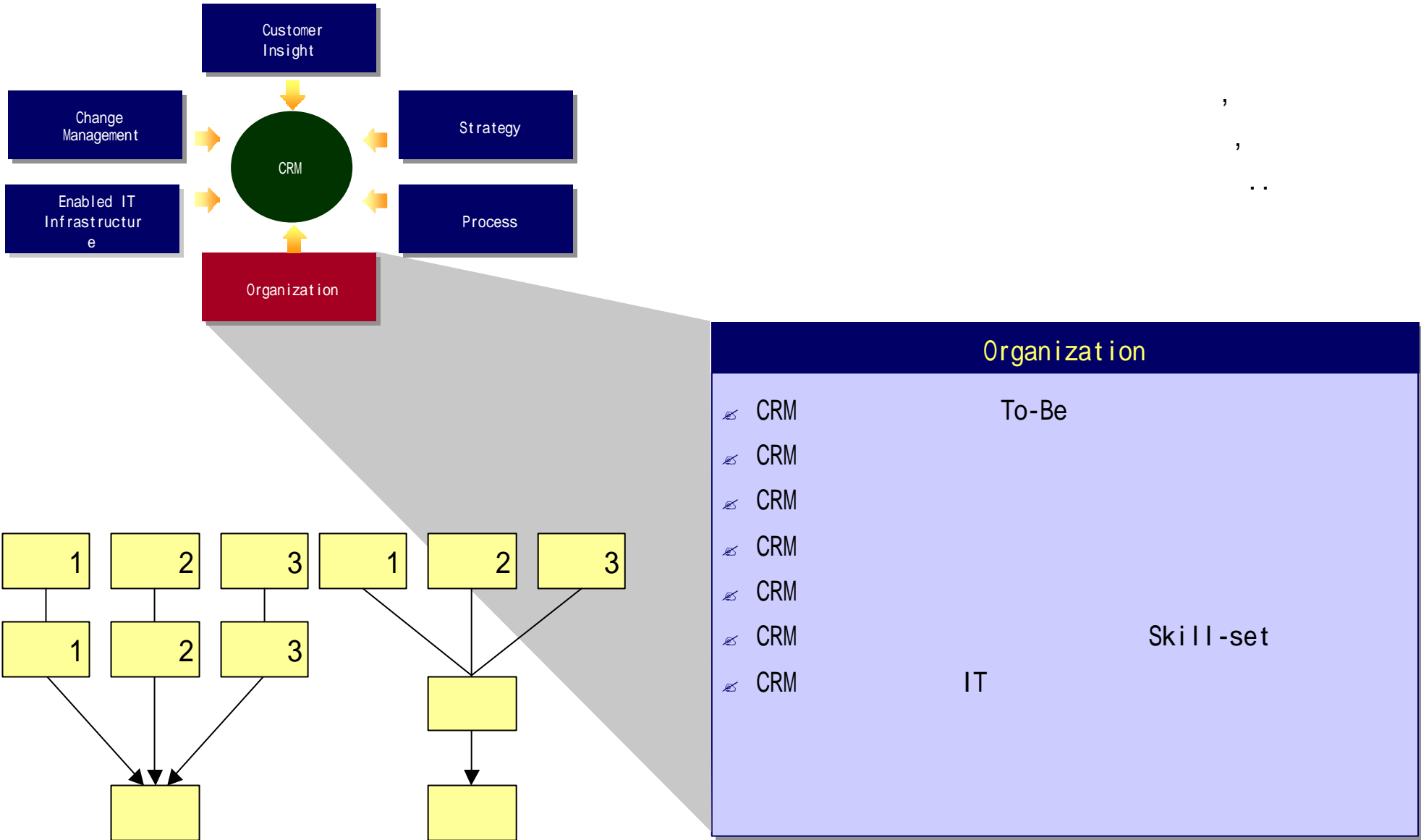

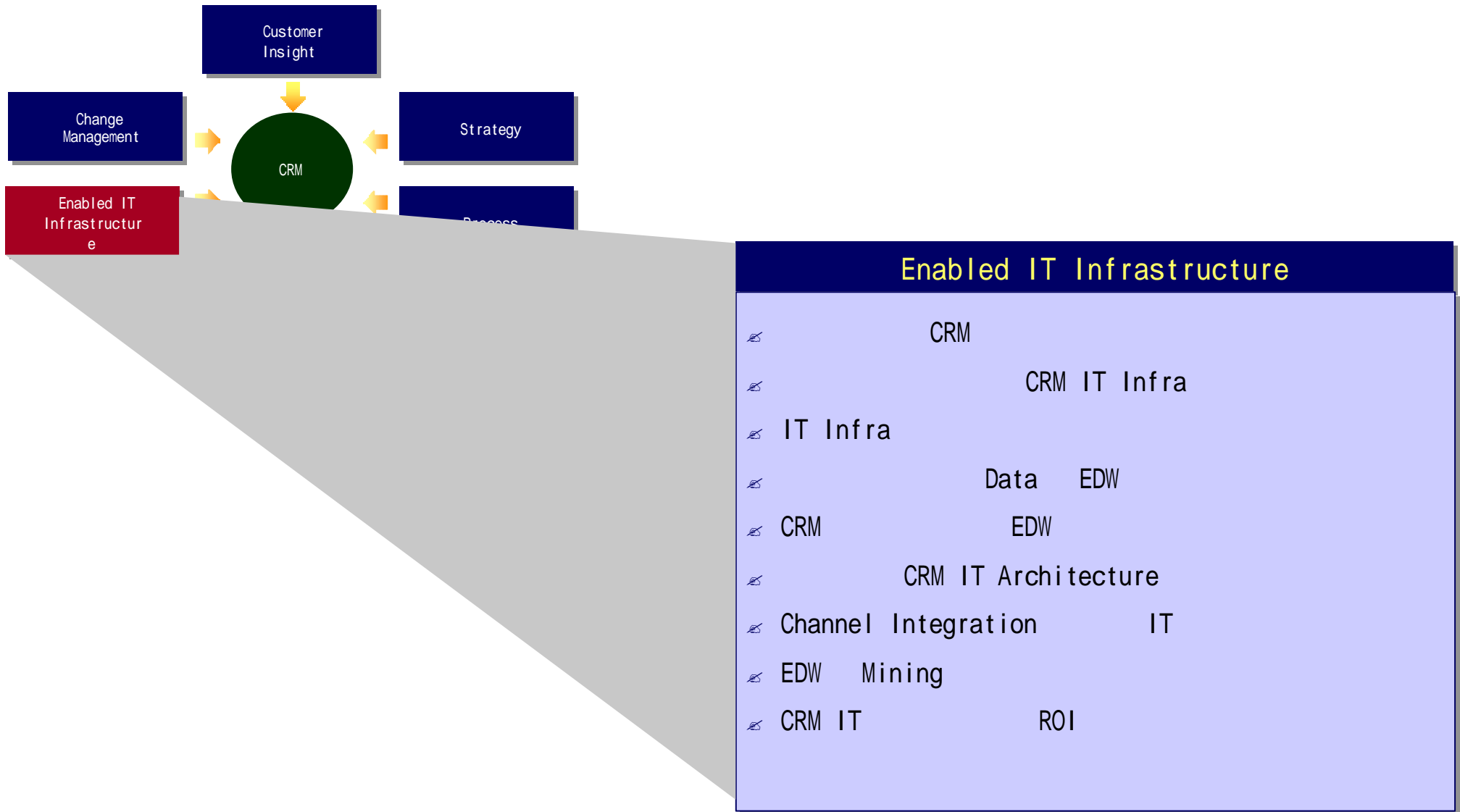

Change Management

