



(Industry Analysis)

2002 3 22

learning.inews24.com

Hipro@HiproConsulting.com

553-8670~1

561-8671

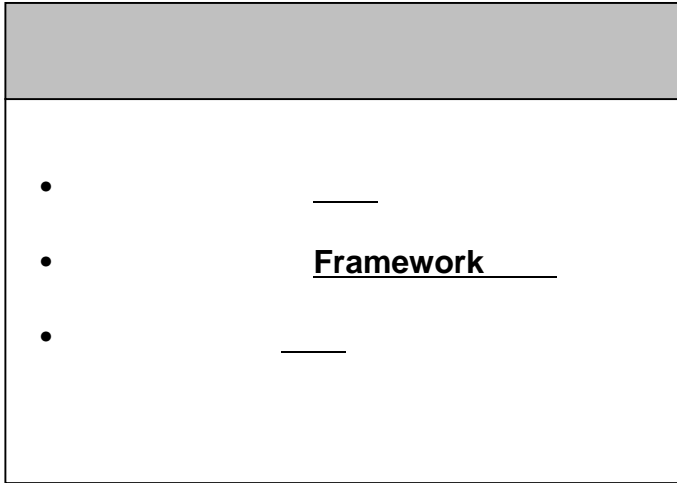
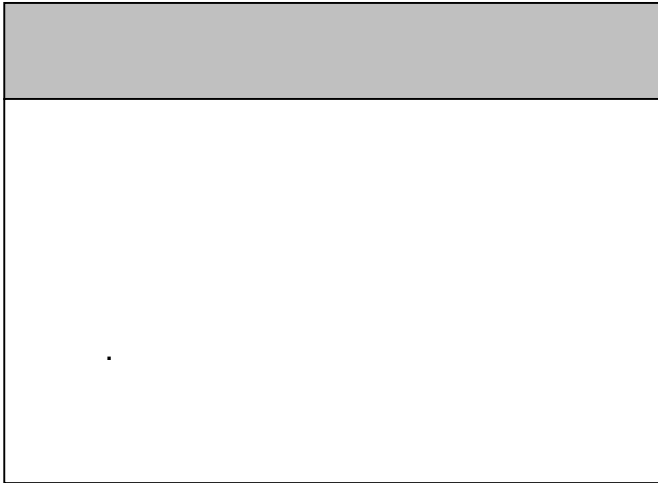
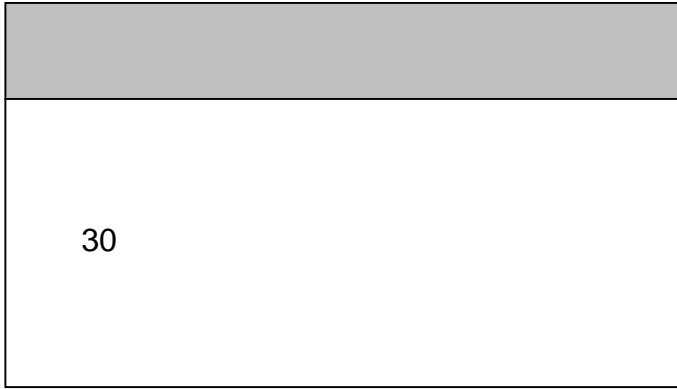
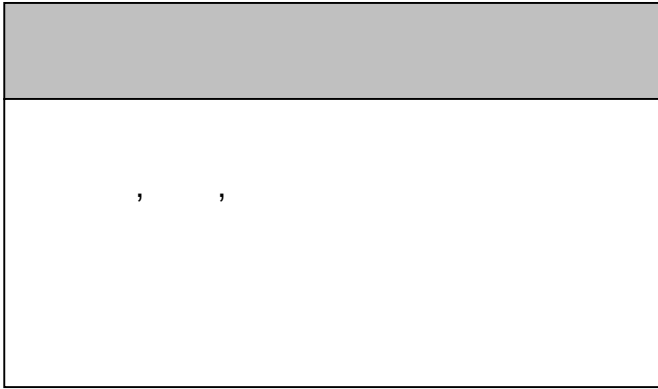

, Framework

3

30~35

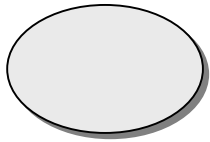
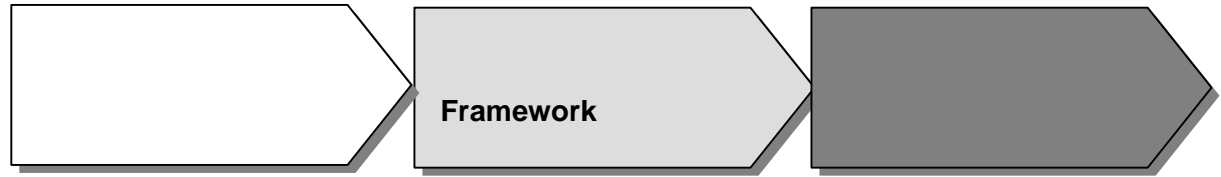

M.Potter

가

Framework



3

20

10

Q

?

가

가

가

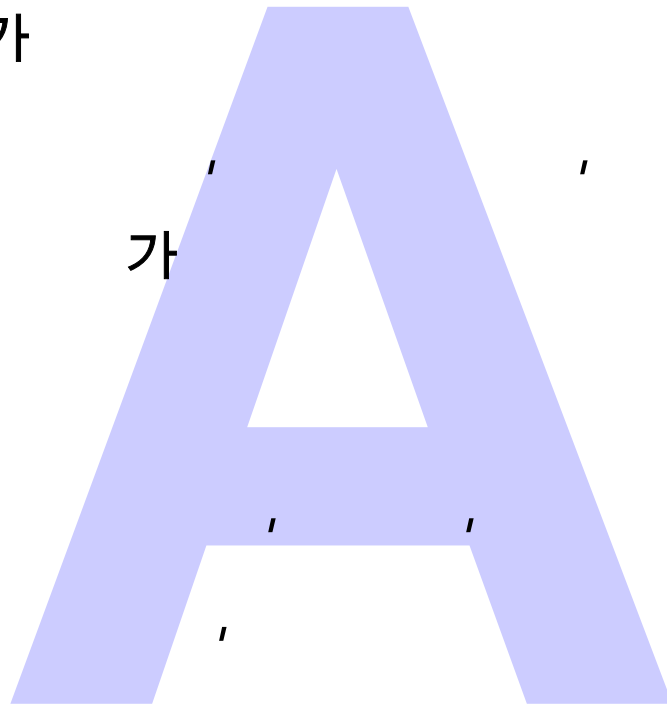

Q

,

가

?

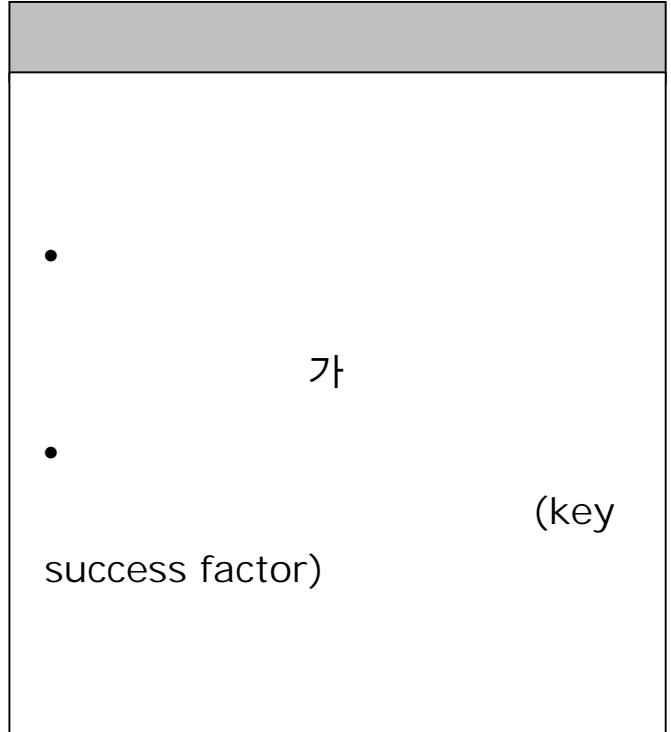
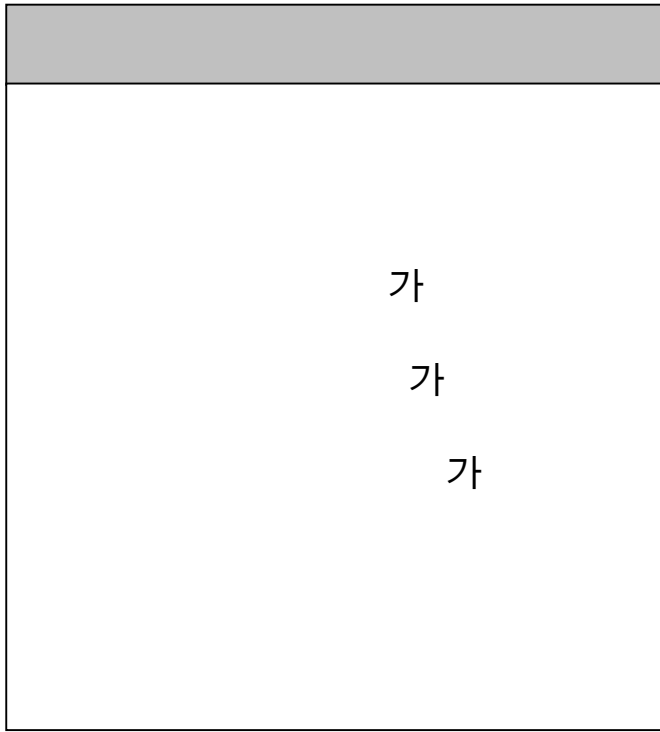

[Blank box]

[Blank box]

가 “ 가 가”

, 가

,

?

Michael Porter Framework

▪

Framework

M. Porter Five Forces Analysis 가

Framework

가

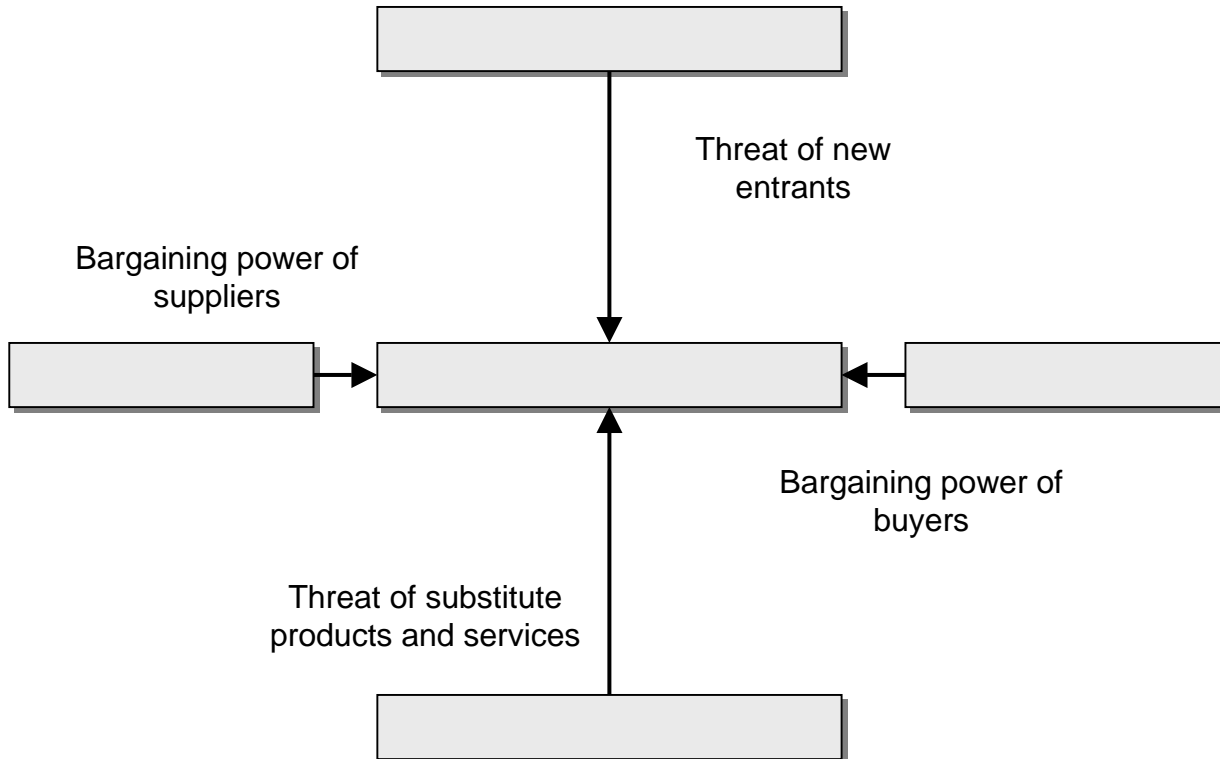

,



■

Drivers –

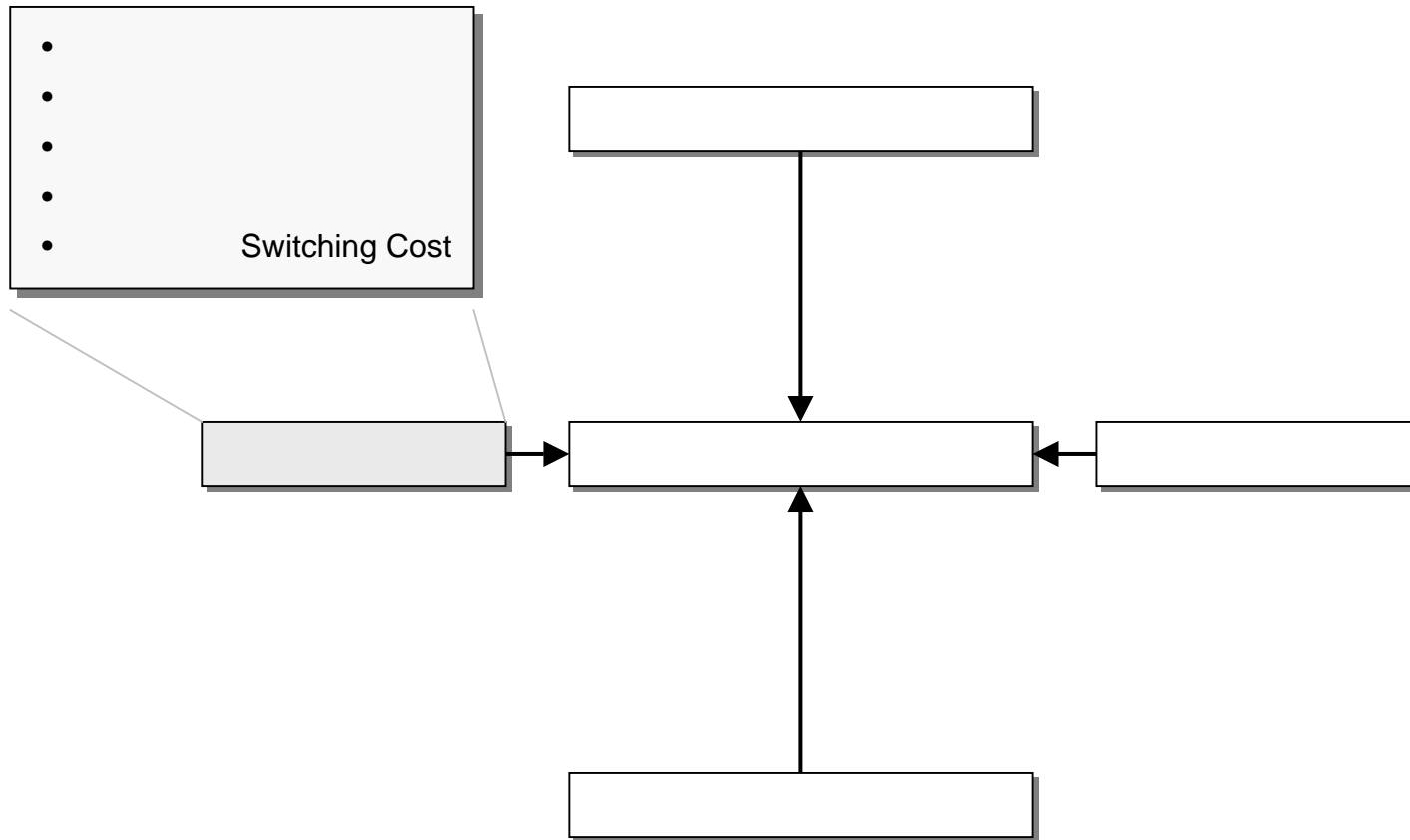

Drivers –

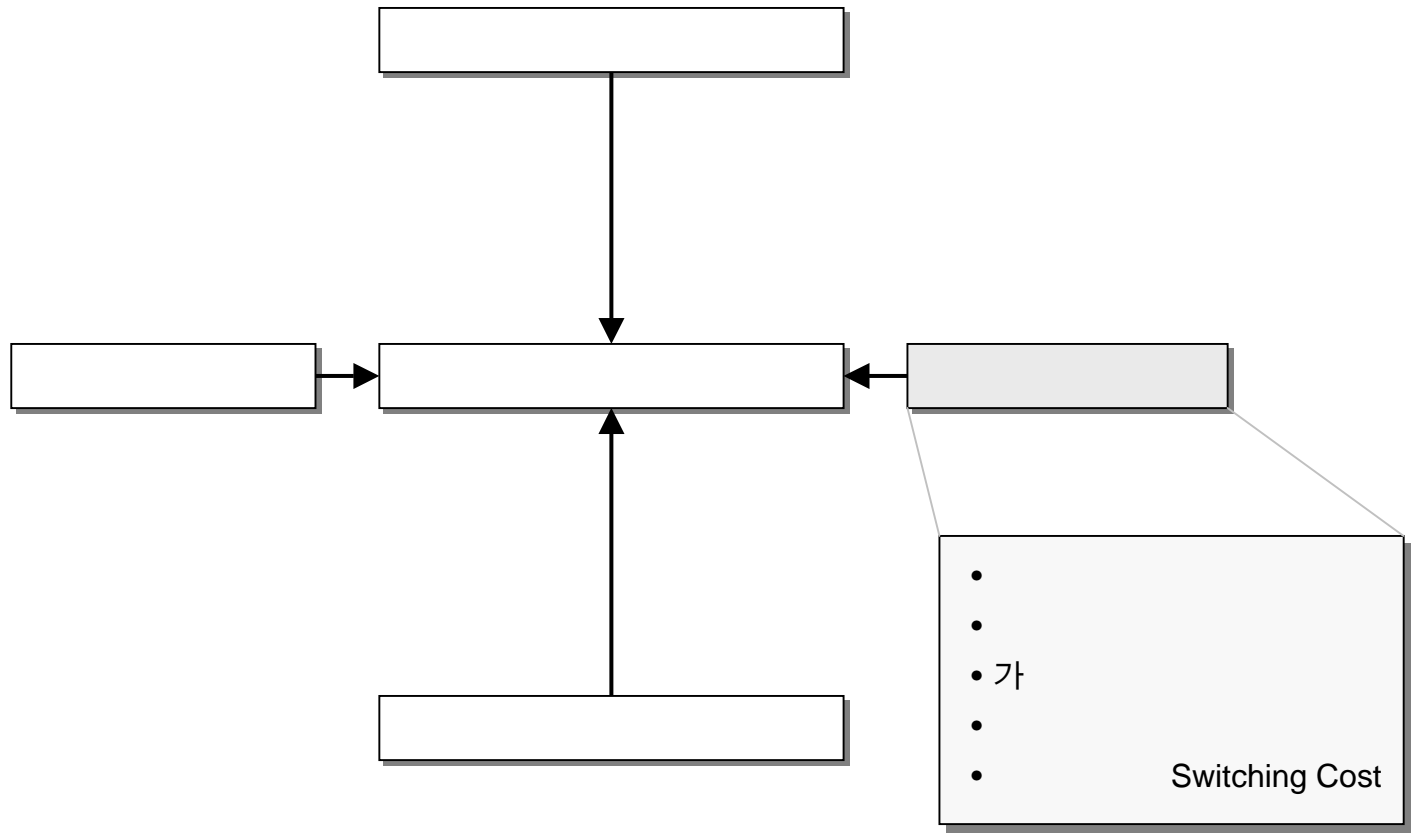

Drivers –

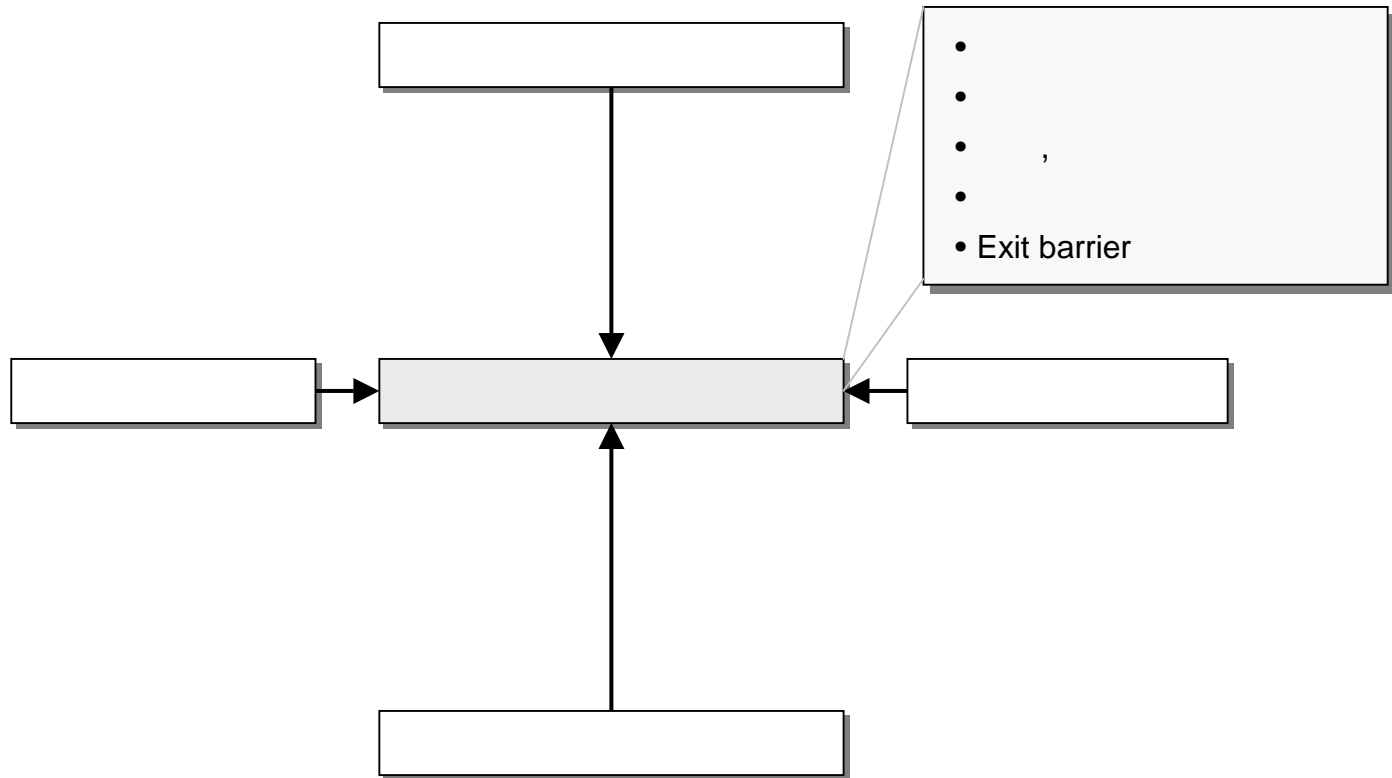

Drivers –

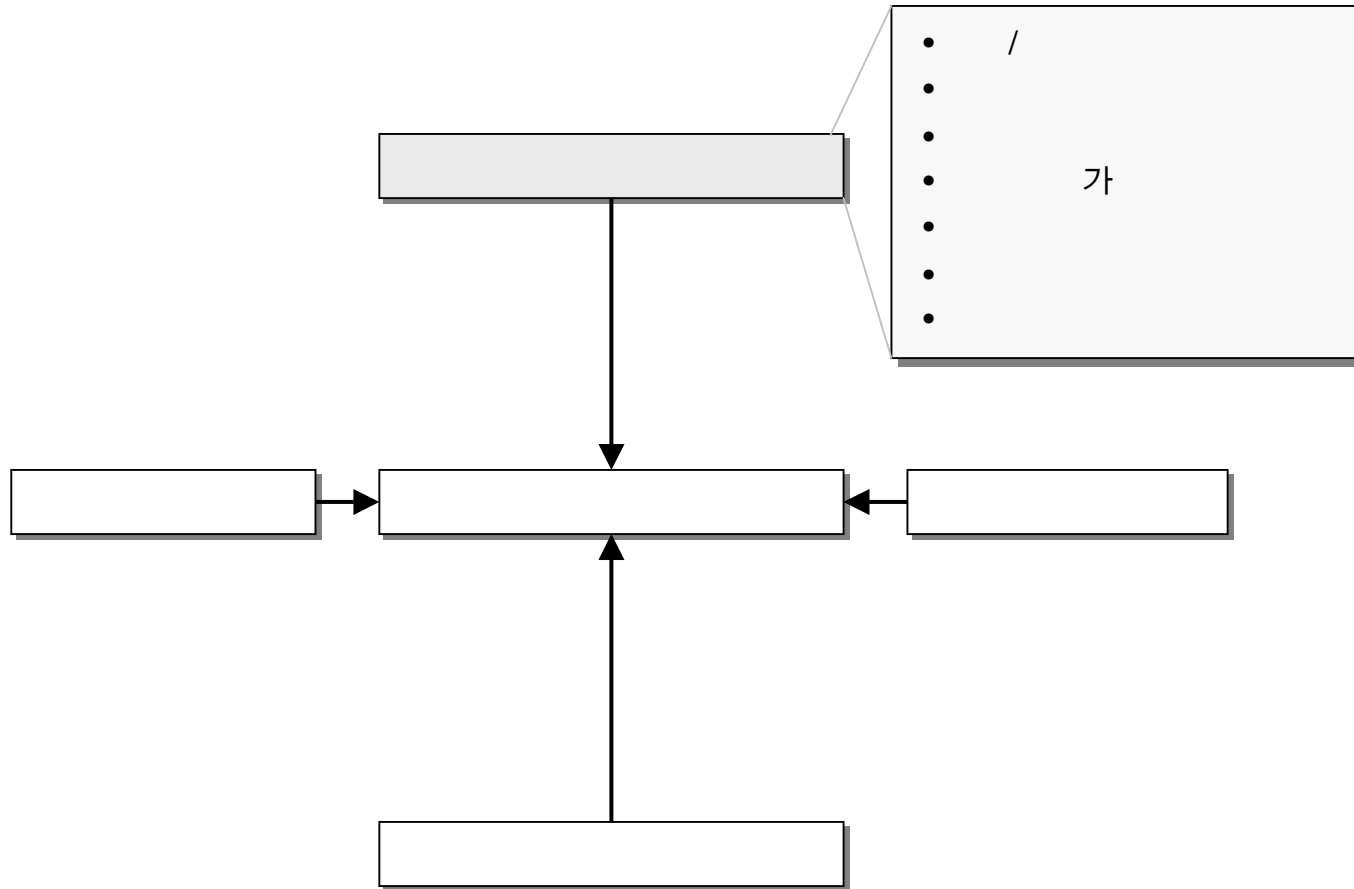

Drivers - /

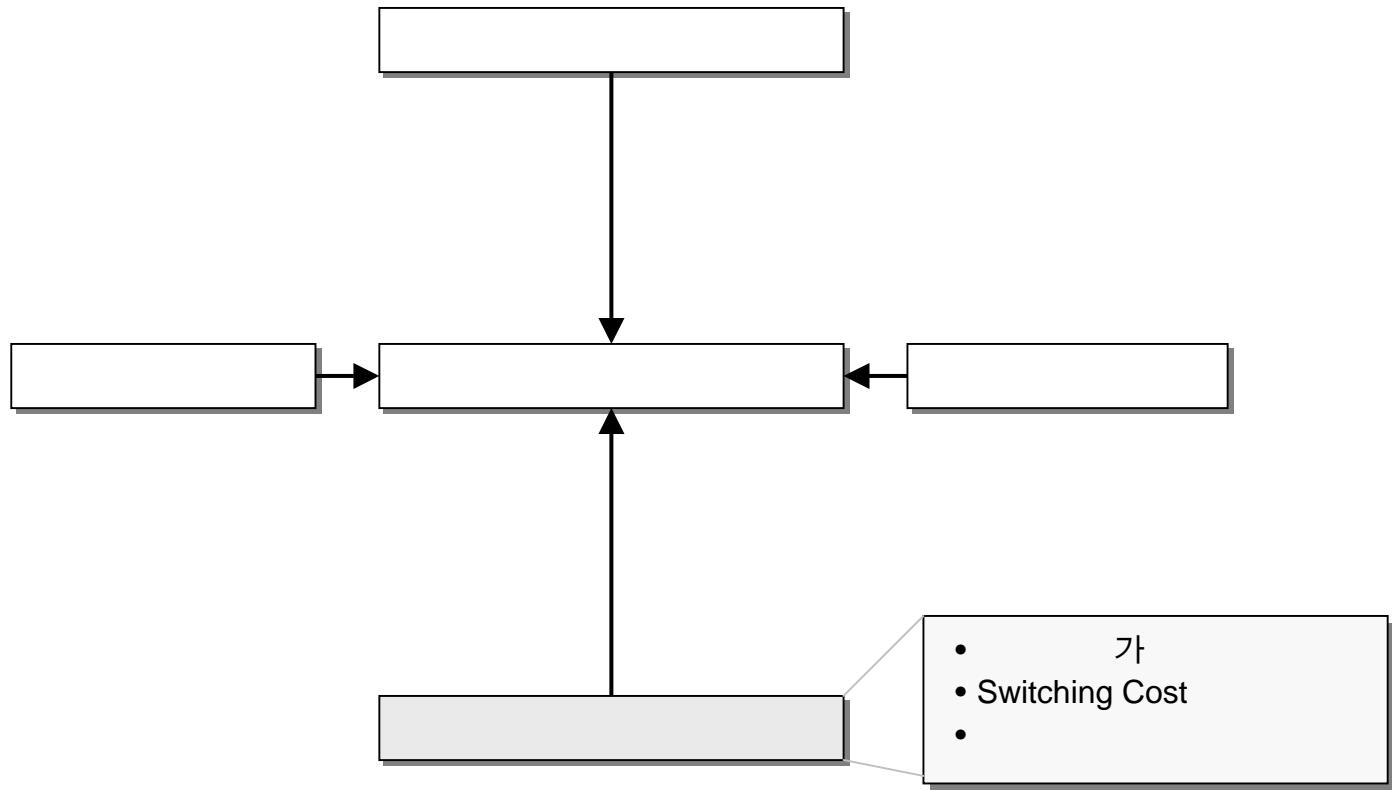

?

Framework

.

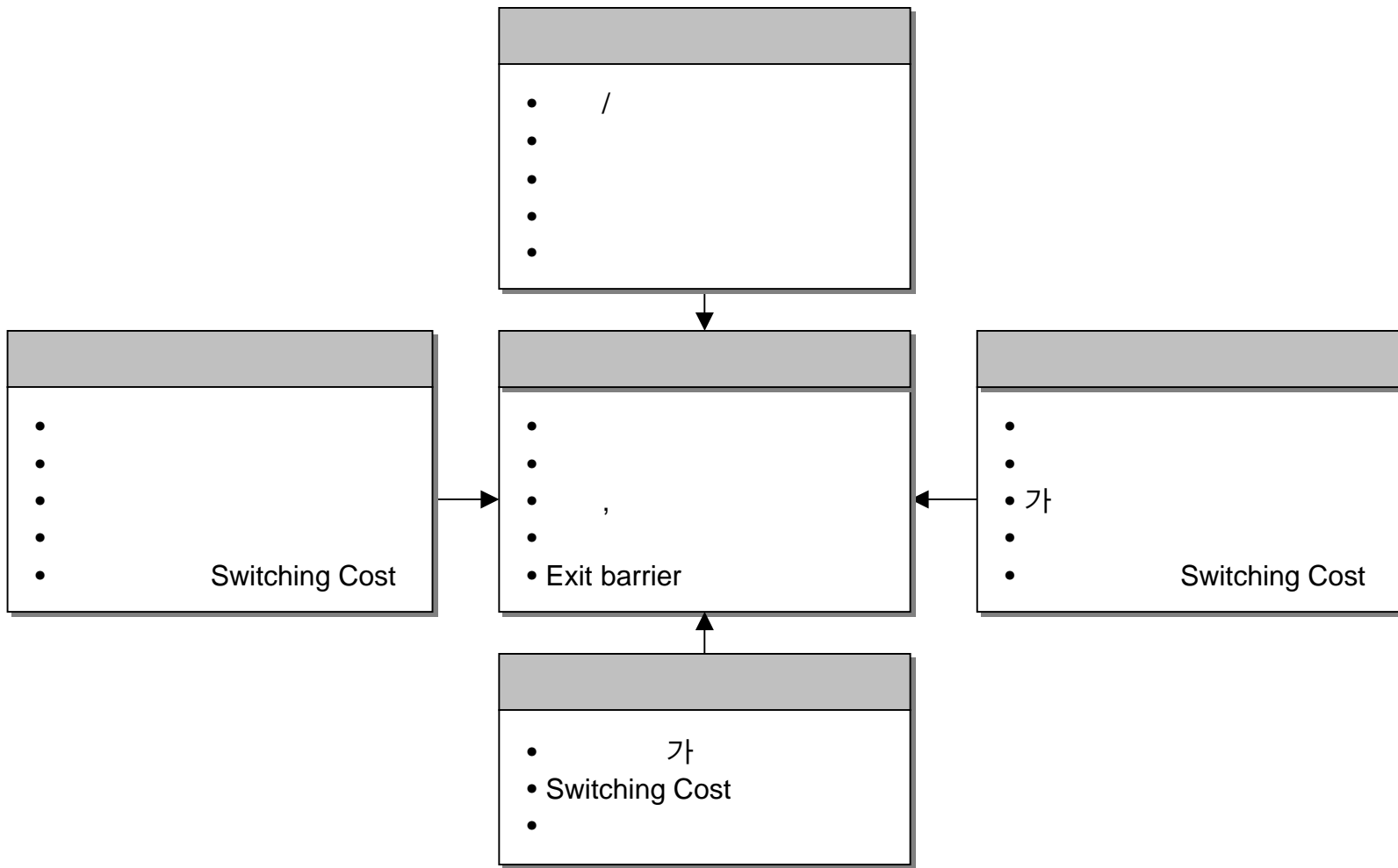

Framework

,

▪

▪

- 2002 2 /on-line

Knowledge Providing Service / on-line
Buying Power

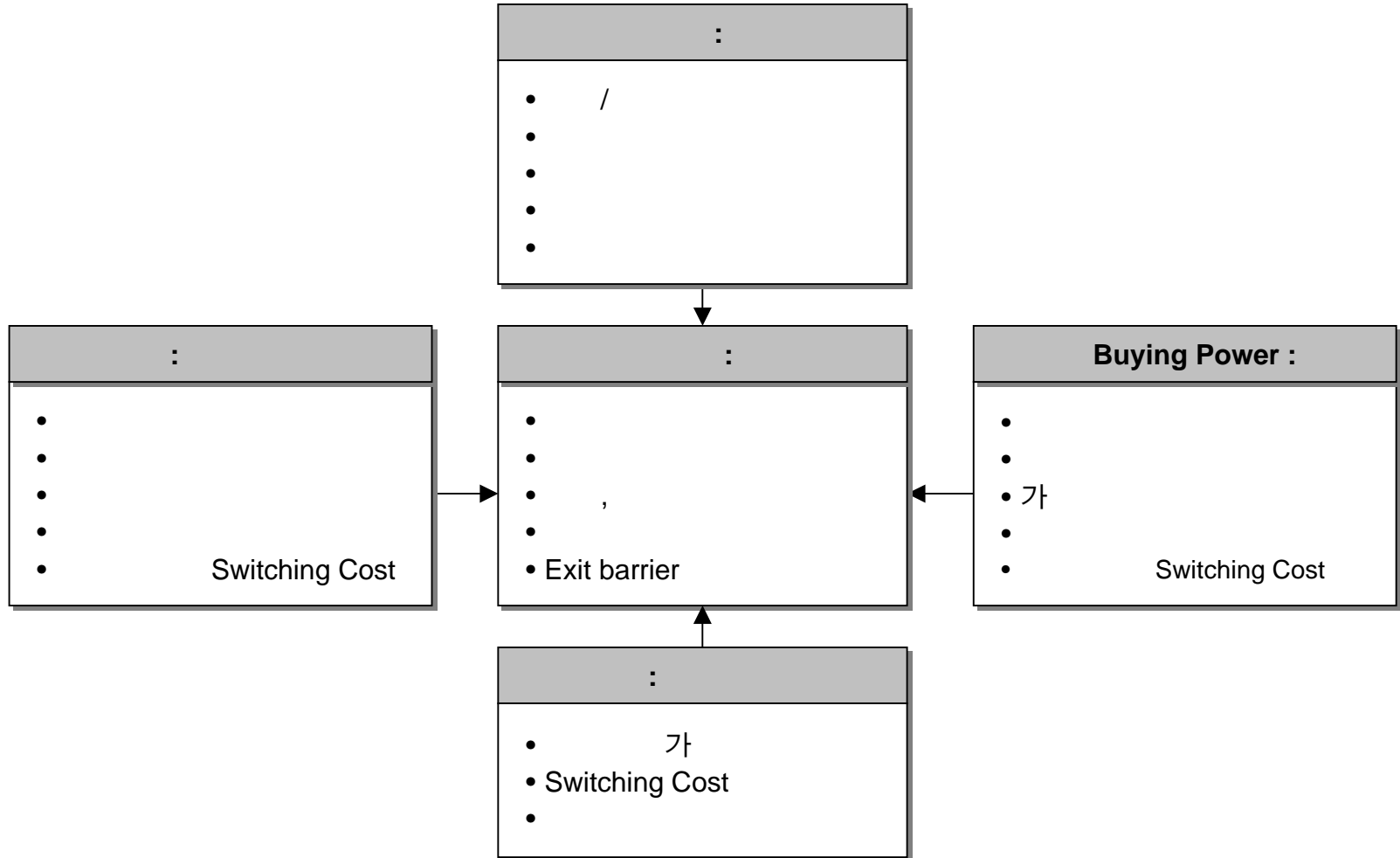

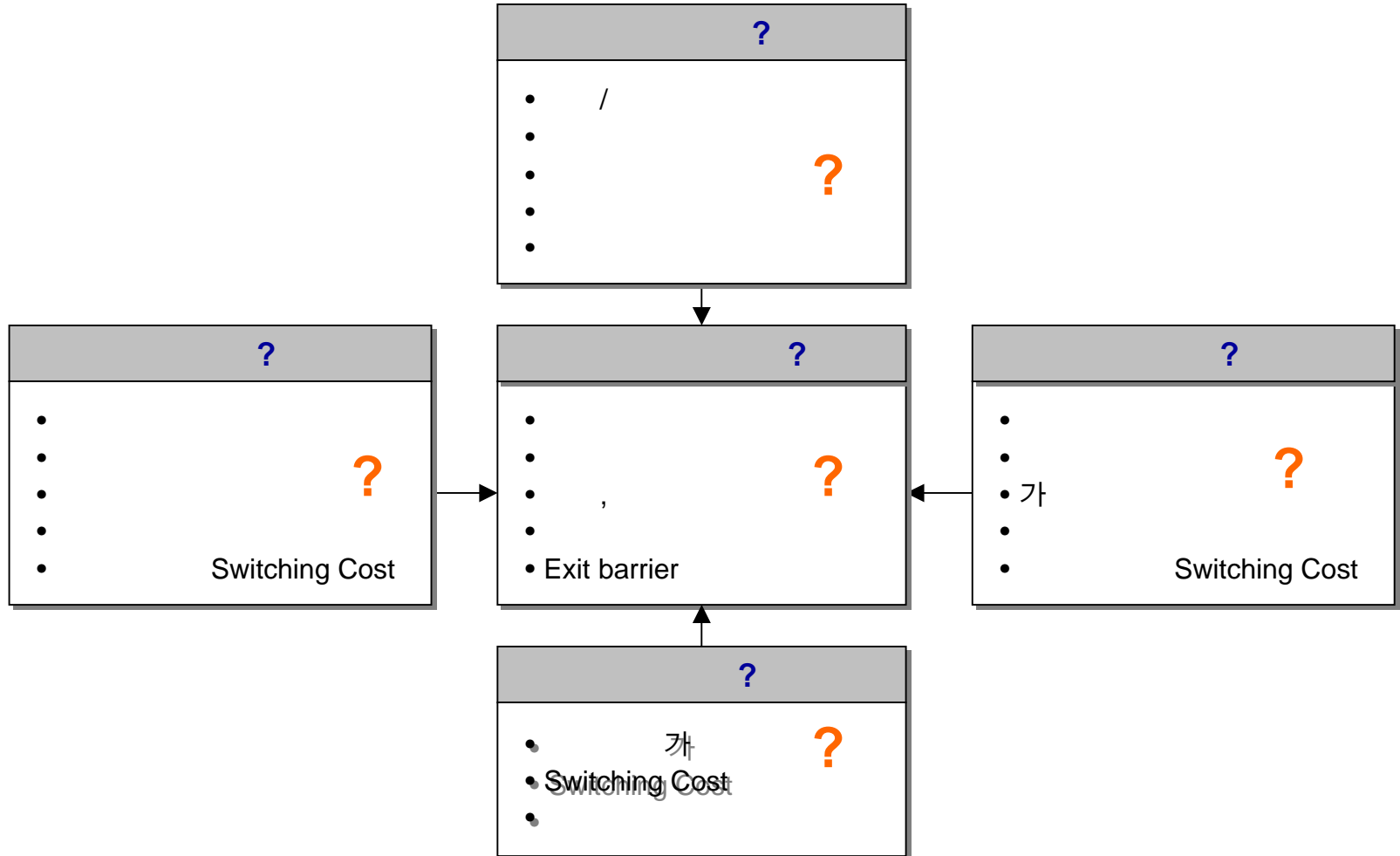

•
•
Framework

가

,

End of Document

Hipro@HiproConsulting.com